

Dell Precision 7820 Tower

Owner's Manual

Notes, cautions, and warnings

 **NOTE:** A NOTE indicates important information that helps you make better use of your product.

 **CAUTION:** A CAUTION indicates either potential damage to hardware or loss of data and tells you how to avoid the problem.

 **WARNING:** A WARNING indicates a potential for property damage, personal injury, or death.

Chapter 1: Chassis	7
Front view.....	7
Back view.....	8
Internal view.....	9
Major components of your system	11
Chapter 2: Working on your computer	13
Safety instructions.....	13
Electrostatic discharge—ESD protection.....	13
ESD field service kit	14
Safety instructions.....	15
Turning off your computer — Windows.....	16
Before working inside your computer.....	16
After working inside your computer.....	16
Chapter 3: Removing and installing components	17
Screw size list.....	17
Recommended tools.....	18
Power supply unit (PSU).....	18
Removing the PSU.....	18
Installing the PSU.....	19
Side cover.....	19
Removing the side cover.....	19
Installing the side cover.....	21
Front bezel.....	21
Removing the front bezel.....	21
Installing the front bezel.....	23
Hard Disk Drive bezel.....	23
Removing HDD bezel.....	23
Installing HDD bezel.....	24
Hard disk drive assembly.....	24
Removing the HDD carrier.....	24
Installing the HDD carrier.....	26
Removing the HDD.....	26
Installing the HDD.....	28
NVMe Flexbay.....	28
Removing the NVMe Flexbay.....	28
Installing the NVMe flexbay.....	31
Slim Optical Disk Drive.....	34
Removing the slim ODD.....	34
Installing the slim ODD.....	35
Front input and output bezel.....	35
Removing front input and output bezel.....	35
Installing front input and output bezel.....	37

5.25 inch ODD bracket.....	37
Removing the 5.25 ODD bracket.....	37
Installing the 5.25 ODD bay.....	40
Front input and output panel.....	40
Removing front input and output panel.....	40
Installing front input and output panel.....	43
Input and output panel bracket.....	44
Removing input and output panel bracket.....	44
Installing input and output panel bracket.....	45
VROC module.....	45
Removing the VROC module.....	45
Installing the VROC module.....	46
Intrusion switch.....	46
Removing the Intrusion switch.....	46
Installing the intrusion switch.....	47
Internal chassis speaker.....	47
Removing the internal chassis speaker.....	47
Installing the internal chassis speaker.....	48
Air shroud.....	49
Removing the air shroud.....	49
Installing the air shroud.....	49
Memory.....	50
Removing the memory module.....	50
Installing the memory module.....	50
Graphical processing unit(GPU).....	50
Removing the GPU.....	50
Installing the GPU.....	52
Coin cell battery.....	52
Removing the coin cell battery.....	52
Installing the coin cell battery.....	53
Center System fan/HDD fan.....	53
Removing the Center System fan/HDD fan.....	53
Installing the Center System fan/HDD fan.....	55
Fan bracket.....	55
Removing the fan from the fan bracket.....	55
Installing the fan into the fan bracket.....	56
PCIe holder.....	57
Removing PCIe holder.....	57
Installing the PCIe holder.....	57
Rear system fan.....	58
Removing the rear system fan.....	58
Installing the rear system fan.....	60
Front system fan.....	60
Removing the front system fan.....	60
Installing the front system fan.....	62
Processor heat sink module.....	63
Removing the processor heat sink module.....	63
Installing the processor heat sink module.....	64
Removing the CPU.....	64
Installing the CPU.....	66

Removing the Riser Card and Dual Processor configuration	69
Installing the Riser Card and Dual Processor configuration	75
System board.....	83
Removing system board.....	83
Installing the system board.....	89
System board components.....	90
Chapter 4: Technology and components.....	91
Memory configuration.....	91
Technologies list.....	93
MegaRAID 9440-8i and 9460-16i controller.....	95
Teradici PCoIP.....	97
Chapter 5: System specifications.....	101
System specifications.....	101
Memory specifications.....	101
Video specifications.....	102
Audio specifications.....	102
Network specifications.....	103
Card slots.....	103
Storage specifications.....	103
External connectors.....	104
Power specifications.....	104
Physical specifications.....	104
Environmental specifications.....	104
CPU utilization matrix for AEP DIMM.....	105
Chapter 6: System Setup.....	107
General options.....	107
System configuration.....	108
Video.....	111
Security.....	111
Secure boot.....	113
Performance.....	114
Power management.....	115
Post behaviour.....	116
Manageability.....	116
Virtualization support.....	117
Maintenance.....	117
System logs.....	118
Advanced configurations.....	118
SupportAssist system resolution.....	118
Updating the BIOS.....	118
Updating the BIOS in Windows.....	118
Updating the BIOS in Linux and Ubuntu.....	119
Updating the BIOS using the USB drive in Windows.....	119
Updating the BIOS from the F12 One Time Boot menu.....	119
MegaRAID controller options.....	120
System and setup password.....	121

Assigning a system setup password.....	121
Deleting or changing an existing system setup password.....	121
Chapter 7: Software.....	122
Operating system.....	122
Downloading drivers.....	122
Chipset drivers.....	123
Graphics controller driver.....	123
Ports.....	123
USB drivers.....	124
Network driver.....	124
Audio drivers.....	124
Storage controller drivers.....	124
Other drivers.....	125
Chapter 8: Troubleshooting.....	126
Dell Enhanced Pre-Boot System Assessment — ePSA Diagnostic 3.0.....	126
Running the ePSA Diagnostics.....	126
Hard drive indicator codes.....	127
Preboot blinking power button codes.....	128
Chapter 9: Contacting Dell.....	132

Chassis

This chapter illustrates the multiple chassis views along with the ports and connectors and also explains the FN hot key combinations.

Topics:

- Front view
- Back view
- Internal view
- Major components of your system

Front view

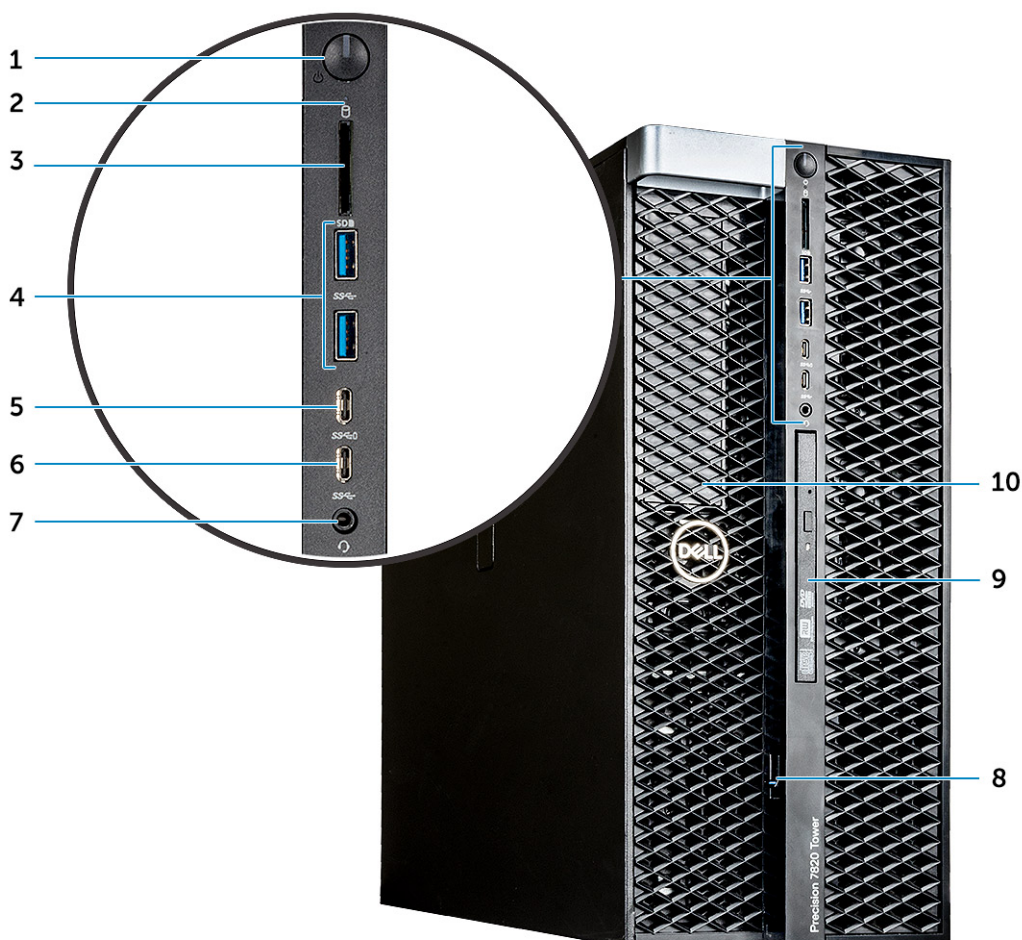

1. Power button
3. SD card slot
5. USB 3.1 Gen 1 Type C port with PowerShare
7. Headset port

2. HDD activity LED
4. USB 3.1 Gen 1 ports
6. USB 3.1 Gen 1 Type C
8. Drive access release latch

9. Slim optical disk drive

10. 5.25 inch ODD bracket

Back view

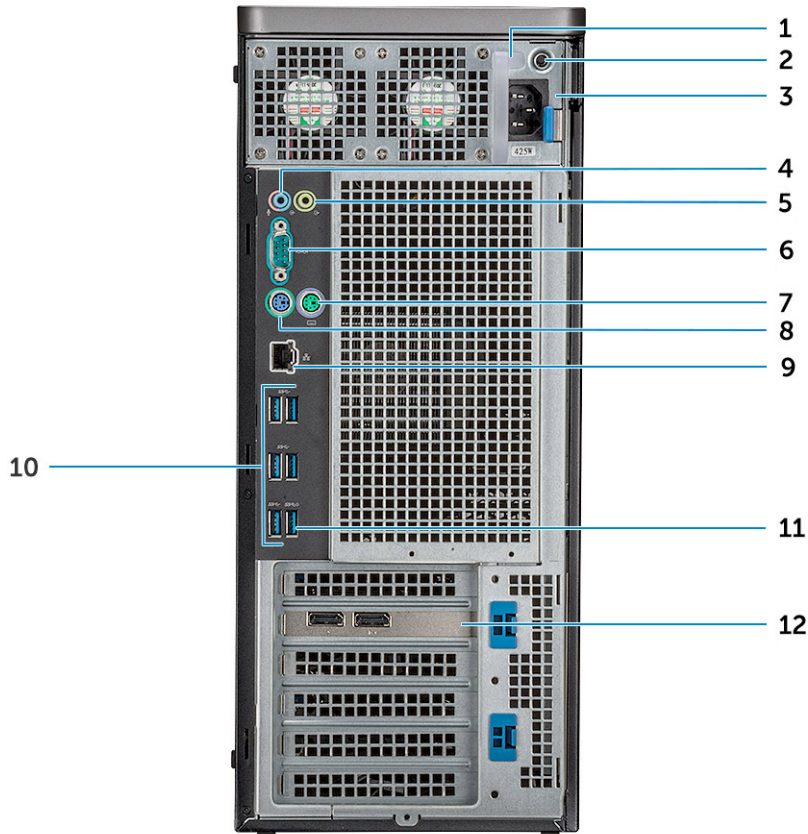

- 1. PSU BIST LED
- 3. Microphone /Line-in port
- 5. Serial port
- 7. PS/2 Keyboard port
- 9. USB 3.1 Gen1 ports
- 11. PCIe expansion slot

- 2. Power supply unit
- 4. Line-out port
- 6. PS/2 Mouse port
- 8. Network port
- 10. USB 3.1 Gen1 port(supports smart Power-On)
- 12. Mechanical expansion slots

Internal view

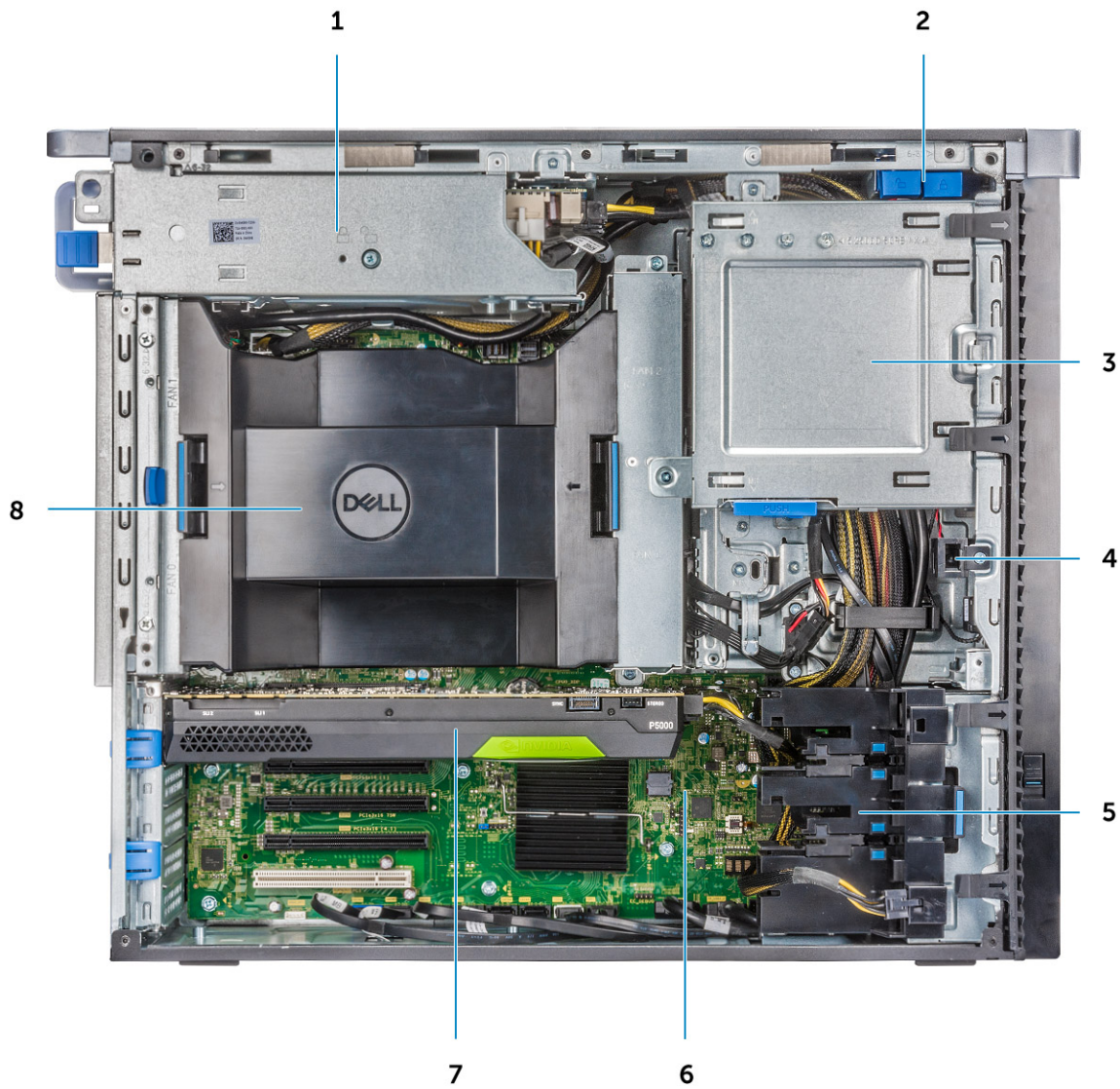

- 1. PSU bracket
- 2. HDD bezel lock/unlock button
- 3. ODD 5.25" bracket
- 4. Intrusion switch
- 5. PCIe holder
- 6. System board
- 7. GPU
- 8. Air shroud

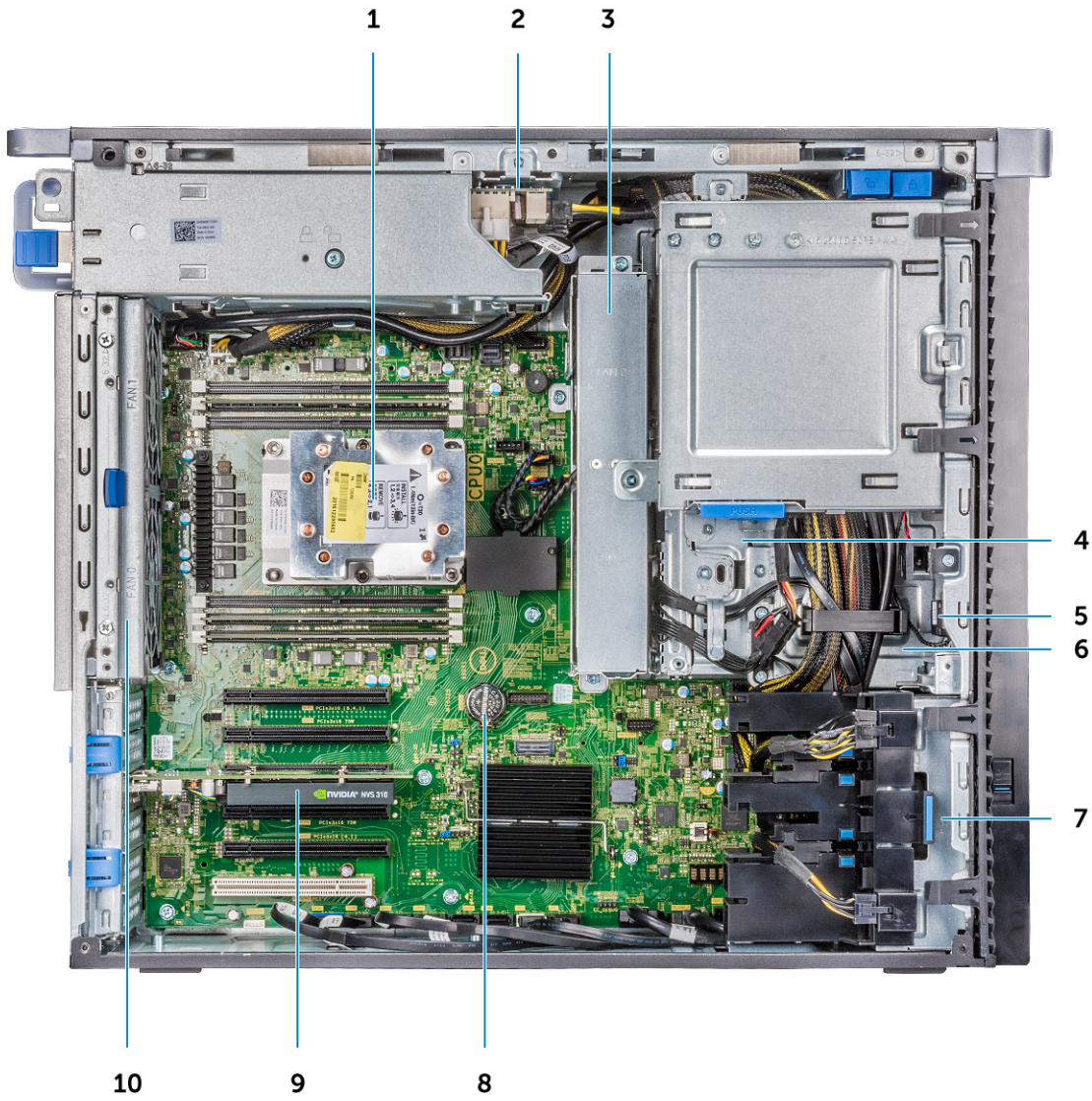

- | | |
|--------------------------|--------------------------------|
| 1. Heat sink | 2. PSU distribution board |
| 3. System fan | 4. 5.25 inch ODD bracket |
| 5. Speaker | 6. 2.5 inch Optical disk drive |
| 7. Front system fan | 8. Coin cell battery |
| 9. Half length PCIe card | 10. Rear system fan |

Major components of your system

This section illustrates the major components of your system along with its location.

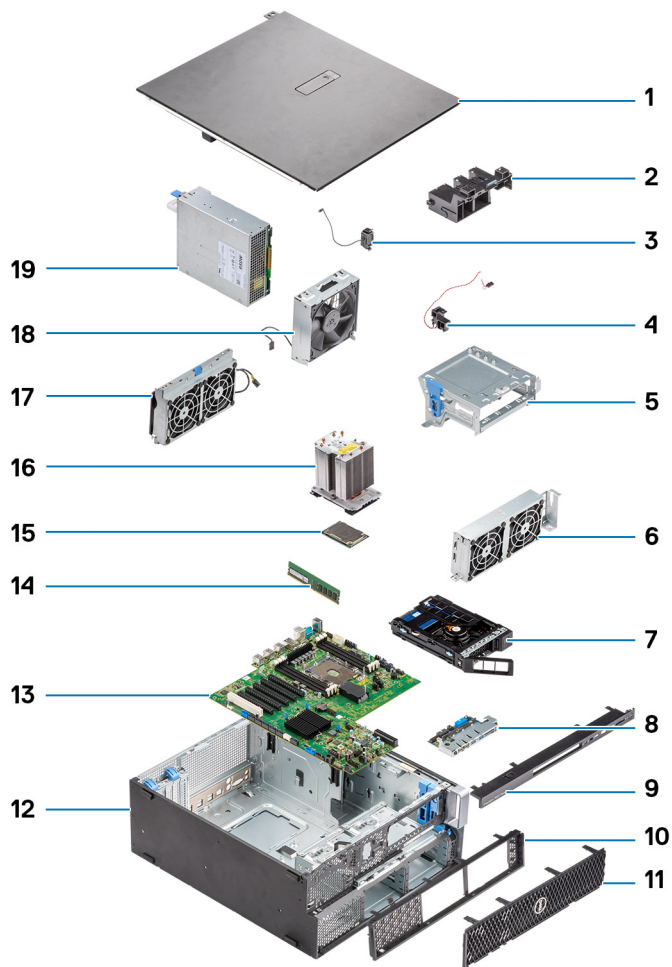

1. Side cover
2. PCIe holder
3. Internal chassis speaker
4. Intrusion switch
5. 5.25 inch ODD bracket
6. System fan
7. NVMe Flexbay
8. Front input and output panel
9. Front input and output bezel
10. Front bezel
11. Hard Disk Drive bezel
12. Computer chassis
13. System board
14. Memory
15. Processor
16. Heat sink and CPU fan assembly
17. System fan
18. Front system fan
19. Power supply unit (PSU)

 **NOTE:** Dell provides a list of components and their part numbers for the original system configuration purchased. These parts are available according to warranty coverages purchased by the customer. Contact your Dell sales representative for purchase options.











Working on your computer

Topics:

- [Safety instructions](#)
- [Turning off your computer — Windows](#)
- [Before working inside your computer](#)
- [After working inside your computer](#)

Safety instructions

Use the following safety guidelines to protect your computer from potential damage and to ensure your personal safety. Unless otherwise noted, each procedure included in this document assumes that you have read the safety information that shipped with your computer.

-  **WARNING:** Before working inside your computer, read the safety information that is shipped with your computer. For more safety best practices, see the Regulatory Compliance home page at www.dell.com/regulatory_compliance.
-  **WARNING:** Disconnect your computer from all power sources before opening the computer cover or panels. After you finish working inside the computer, replace all covers, panels, and screws before connecting your computer to an electrical outlet.
-  **CAUTION:** To avoid damaging the computer, ensure that the work surface is flat, dry, and clean.
-  **CAUTION:** To avoid damaging the components and cards, handle them by their edges, and avoid touching the pins and the contacts.
-  **CAUTION:** You should only perform troubleshooting and repairs as authorized or directed by the Dell technical assistance team. Damage due to servicing that is not authorized by Dell is not covered by your warranty. See the safety instructions that is shipped with the product or at www.dell.com/regulatory_compliance.
-  **CAUTION:** Before touching anything inside your computer, ground yourself by touching an unpainted metal surface, such as the metal at the back of the computer. While you work, periodically touch an unpainted metal surface to dissipate static electricity which could harm internal components.
-  **CAUTION:** When you disconnect a cable, pull it by its connector or its pull tab, not the cable itself. Some cables have connectors with locking tabs or thumbscrews that you must disengage before disconnecting the cable. When disconnecting cables, keep them evenly aligned to avoid bending the connector pins. When connecting cables, ensure that the ports and the connectors are correctly oriented and aligned.
-  **CAUTION:** Press and eject any installed card from the media-card reader.
-  **CAUTION:** Exercise caution when handling rechargeable Li-ion batteries in laptops. Swollen batteries should not be used and should be replaced and disposed properly.
-  **NOTE:** The color of your computer and certain components may appear differently than shown in this document.

Electrostatic discharge—ESD protection

ESD is a major concern when you handle electronic components, especially sensitive components such as expansion cards, processors, memory DIMMs, and system boards. Very slight charges can damage circuits in ways that may not be obvious, such

as intermittent problems or a shortened product life span. As the industry pushes for lower power requirements and increased density, ESD protection is an increasing concern.

Due to the increased density of semiconductors used in recent Dell products, the sensitivity to static damage is now higher than in previous Dell products. For this reason, some previously approved methods of handling parts are no longer applicable.

Two recognized types of ESD damage are catastrophic and intermittent failures.

- **Catastrophic** – Catastrophic failures represent approximately 20 percent of ESD-related failures. The damage causes an immediate and complete loss of device functionality. An example of catastrophic failure is a memory DIMM that has received a static shock and immediately generates a "No POST/No Video" symptom with a beep code emitted for missing or nonfunctional memory.
- **Intermittent** – Intermittent failures represent approximately 80 percent of ESD-related failures. The high rate of intermittent failures means that most of the time when damage occurs, it is not immediately recognizable. The DIMM receives a static shock, but the tracing is merely weakened and does not immediately produce outward symptoms related to the damage. The weakened trace may take weeks or months to melt, and in the meantime may cause degradation of memory integrity, intermittent memory errors, etc.

The more difficult type of damage to recognize and troubleshoot is the intermittent (also called latent or "walking wounded") failure.

Perform the following steps to prevent ESD damage:

- Use a wired ESD wrist strap that is properly grounded. The use of wireless anti-static straps is no longer allowed; they do not provide adequate protection. Touching the chassis before handling parts does not ensure adequate ESD protection on parts with increased sensitivity to ESD damage.
- Handle all static-sensitive components in a static-safe area. If possible, use anti-static floor pads and workbench pads.
- When unpacking a static-sensitive component from its shipping carton, do not remove the component from the anti-static packing material until you are ready to install the component. Before unwrapping the anti-static packaging, ensure that you discharge static electricity from your body.
- Before transporting a static-sensitive component, place it in an anti-static container or packaging.

ESD field service kit

The unmonitored Field Service kit is the most commonly used service kit. Each Field Service kit includes three main components: anti-static mat, wrist strap, and bonding wire.

Components of an ESD field service kit

The components of an ESD field service kit are:

- **Anti-Static Mat** – The anti-static mat is dissipative and parts can be placed on it during service procedures. When using an anti-static mat, your wrist strap should be snug and the bonding wire should be connected to the mat and to any bare metal on the computer being worked on. Once deployed properly, service parts can be removed from the ESD bag and placed directly on the mat. ESD-sensitive items are safe in your hand, on the ESD mat, in the computer, or inside a bag.
- **Wrist Strap and Bonding Wire** – The wrist strap and bonding wire can be either directly connected between your wrist and bare metal on the hardware if the ESD mat is not required, or connected to the anti-static mat to protect hardware that is temporarily placed on the mat. The physical connection of the wrist strap and bonding wire between your skin, the ESD mat, and the hardware is known as bonding. Use only Field Service kits with a wrist strap, mat, and bonding wire. Never use wireless wrist straps. Always be aware that the internal wires of a wrist strap are prone to damage from normal wear and tear, and must be checked regularly with a wrist strap tester in order to avoid accidental ESD hardware damage. It is recommended to test the wrist strap and bonding wire at least once per week.
- **ESD Wrist Strap Tester** – The wires inside an ESD strap are prone to damage over time. When using an unmonitored kit, it is a best practice to regularly test the strap prior to each service call, and at a minimum, test once per week. A wrist strap tester is the best method for doing this test. If you do not have your own wrist strap tester, check with your regional office to find out if they have one. To perform the test, plug the wrist-strap's bonding-wire into the tester while it is strapped to your wrist and push the button to test. A green LED is lit if the test is successful; a red LED is lit and an alarm sounds if the test fails.
- **Insulator Elements** – It is critical to keep ESD sensitive devices, such as plastic heat sink casings, away from internal parts that are insulators and often highly charged.
- **Working Environment** – Before deploying the ESD Field Service kit, assess the situation at the customer location. For example, deploying the kit for a server environment is different than for a desktop or laptop environment. Servers are typically installed in a rack within a data center; desktops or laptops are typically placed on office desks or cubicles. Always look for a large open flat work area that is free of clutter and large enough to deploy the ESD kit with additional space to accommodate the type of computer that is being repaired. The workspace should also be free of insulators that can cause an

ESD event. On the work area, insulators such as Styrofoam and other plastics should always be moved at least 12 inches or 30 centimeters away from sensitive parts before physically handling any hardware components

- **ESD Packaging** – All ESD-sensitive devices must be shipped and received in static-safe packaging. Metal, static-shielded bags are preferred. However, you should always return the damaged part using the same ESD bag and packaging that the new part arrived in. The ESD bag should be folded over and taped shut and all the same foam packing material should be used in the original box that the new part arrived in. ESD-sensitive devices should be removed from packaging only at an ESD-protected work surface, and parts should never be placed on top of the ESD bag because only the inside the bag is shielded. Always place parts in your hand, on the ESD mat, in the computer, or inside an anti-static bag.
- **Transporting Sensitive Components** – When transporting ESD sensitive components such as replacement parts or parts to be returned to Dell, it is critical to place these parts in anti-static bags for safe transport.

ESD protection summary

It is recommended to use the traditional wired ESD grounding wrist strap and protective anti-static mat always when servicing Dell products. In addition, it is critical to keep sensitive parts separate from all insulator parts while performing service and that they use anti-static bags for transporting sensitive components.

Safety instructions

Use the following safety guidelines to protect your computer from potential damage and to ensure your personal safety. Unless otherwise noted, each procedure included in this document assumes that the following conditions exist:

- You have read the safety information that shipped with your computer.
- A component can be replaced or, if purchased separately, installed by performing the removal procedure in reverse order.

 **WARNING:** Before working inside your computer, read the safety information that shipped with your computer. For additional safety best practices information, see the [Regulatory Compliance Homepage](#)

 **CAUTION:** Many repairs may only be done by a certified service technician. You should only perform troubleshooting and simple repairs as authorized in your product documentation, or as directed by the online or telephone service and support team. Damage due to servicing that is not authorized by Dell is not covered by your warranty. Read and follow the safety instructions that came with the product.

 **CAUTION:** To avoid electrostatic discharge, ground yourself by using a wrist grounding strap or by periodically touching an unpainted metal surface at the same time as touching a connector on the back of the computer.

 **CAUTION:** Handle components and cards with care. Do not touch the components or contacts on a card. Hold a card by its edges or by its metal mounting bracket. Hold a component such as a processor by its edges, not by its pins.

 **CAUTION:** When you disconnect a cable, pull on its connector or on its pull-tab, not on the cable itself. Some cables have connectors with locking tabs; if you are disconnecting this type of cable, press in on the locking tabs before you disconnect the cable. As you pull connectors apart, keep them evenly aligned to avoid bending any connector pins. Also, before you connect a cable, ensure that both connectors are correctly oriented and aligned.

 **NOTE:** Disconnect all power sources before opening the computer cover or panels. After you finish working inside the computer, replace all covers, panels, and screws before connecting to the power source.



 **CAUTION:** Exercise caution when handling Lithium-ion batteries in laptops. Swollen batteries should not be used and should be replaced and disposed properly.

 **NOTE:** The color of your computer and certain components may appear differently than shown in this document.

 **CAUTION:** System will shut down if side covers are removed while the system is running. The system will not power on if the side cover is removed.



Turning off your computer — Windows

 **CAUTION:** To avoid losing data, save and close all open files and exit all open programs before you turn off your computer or remove the side cover.

1. Click or tap .
2. Click or tap  and then click or tap **Shut down**.
 -  **NOTE:** Ensure that the computer and all attached devices are turned off. If your computer and attached devices did not automatically turn off when you shut down your operating system, press and hold the power button for about 6 seconds to turn them off.

Before working inside your computer

 **NOTE:** The images in this document may differ from your computer depending on the configuration you ordered.

1. Save and close all open files and exit all open applications.
2. Shut down your computer. For Windows operating system, click **Start** >  **Power** > **Shut down**.
 -  **NOTE:** If you are using a different operating system, see the documentation of your operating system for shut-down instructions.
3. Disconnect your computer and all attached devices from their electrical outlets.
4. Disconnect all attached network devices and peripherals, such as keyboard, mouse, and monitor from your computer.
 -  **CAUTION:** To disconnect a network cable, first unplug the cable from your computer and then unplug the cable from the network device.
5. Remove any media card and optical disc from your computer, if applicable.

After working inside your computer

 **NOTE:** Leaving stray or loose screws inside your computer may severely damage your computer.

1. Replace all screws and ensure that no stray screws remain inside your computer.
2. Connect any external devices, peripherals, or cables you removed before working on your computer.
3. Replace any media cards, discs, or any other parts that you removed before working on your computer.
4. Connect your computer and all attached devices to their electrical outlets.
5. Turn on your computer.

Removing and installing components

Topics:

- Screw size list
- Recommended tools
- Power supply unit (PSU)
- Side cover
- Front bezel
- Hard Disk Drive bezel
- Hard disk drive assembly
- NVMe Flexbay
- Slim Optical Disk Drive
- Front input and output bezel
- 5.25 inch ODD bracket
- Front input and output panel
- Input and output panel bracket
- VROC module
- Intrusion switch
- Internal chassis speaker
- Air shroud
- Memory
- Graphical processing unit(GPU)
- Coin cell battery
- Center System fan/HDD fan
- Fan bracket
- PCIe holder
- Rear system fan
- Front system fan
- Processor heat sink module
- System board

Screw size list

Table 1. Screw list

Component	Screw type	Quantity
Slim ODD Bracket	#6-32 UNC X6.0mm	1
FIO Cable Clip	#6-32X1/4 inches	1
FIO Board	M3X5.0mm	2
FIO Bracket	#6-32 UNC X6.0mm	1
Front System Fan Bracket	#6-32 UNC X6.0mm	1
Intrusion Holder	M3X5.0mm	1
PDB Board	#6-32X1/4 inches	3
PDB Bracket	M3X5.0mm	1
Slim ODD Plug	M3X5.0mm	2

Table 1. Screw list (continued)

Component	Screw type	Quantity
HDD Bracket	M3X5.0mm	1
5.25" ODD Bracket	#6-32 UNC X6.0mm	2
	M3X5.0mm	2
System Board	#6-32X1/4 inches	11
Middle Fan Fixed Bracket	#6-32X1/4 inches	1
Middle Fan Bracket	#6-32X1/4 inches	3
Rear Fan Bracket	#6-32X1/4 inches	2
HSBP Board	M3X5.0mm	2
Slim ODD Fixed Bracket	M2X2.0mm	2
Slim ODD	M3X5.0mm	1
5.25" ODD	M3X4.5mm	4
3.5" HDD Bracket	M3X4.5mm	4
2.5" HDD Bracket	M3X4.5mm	4
2nd CPU Support Bracket	#6-32X1/4 inches	2
2nd CPU Board	#6-32X1/4 inches	5
UPI Fixed Bracket	M3X5.0mm	1
CPU Cooler	T-30 torx bolt	4
Liquid Cooler Module	#6-32X1/4 inches	4
	#6-32 UNC X3.5mm	6
	T-30 torx bolt	4

Recommended tools

The procedures in this document may require the following tools:

- Phillips #0 screwdriver
- Phillips #1 screwdriver
- Philips #2 screwdriver
- Plastic scribe-Recommended for field technician
- T-30 torx screwdriver

Power supply unit (PSU)

Removing the PSU

1. Follow the procedure in [Before working inside your computer](#).
2. Disconnect the power cable from the system.
3. Press the PSU release latch [1] and slide the power supply away from the system [2].

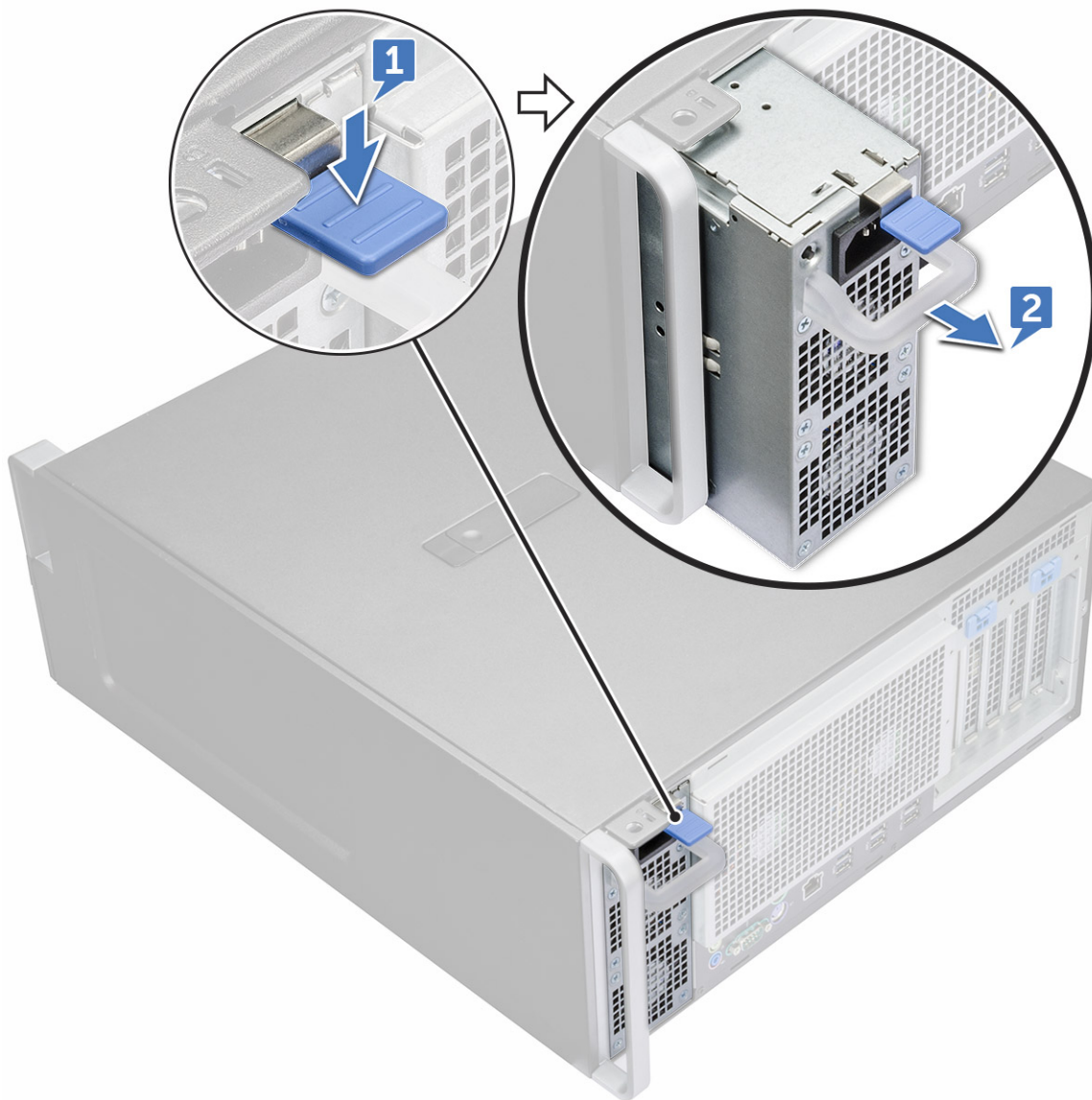

Installing the PSU

1. Slide in the power supply unit to the PSU slot on the system.
2. Connect the power cable to the system.
3. Follow the procedure in [After working inside your computer](#)

Side cover

Removing the side cover

1. Follow the procedure in [Before working inside your computer](#).

 **CAUTION:** The system will not power on while the side cover is off. Also, the system will shut down if the side cover is removed while the system is on.

2. To remove the side cover:
3. Press the latch



4. Pull the latch [1] upward and rotate it to release the cover [2].



5. Lift the cover to remove it from the system.

Installing the side cover

1. First hold and align the bottom of the side cover to the chassis.
2. Ensure that the hook on the bottom of the side cover snaps into the notch on the system.
3. Press the system cover until it clicks into place.

CAUTION: The system will not power on without the side cover. Also, the system will shut down if the side cover is removed while the system is on.

4. Follow the procedure in [After working inside your computer](#) .

Front bezel

Removing the front bezel

1. Follow the procedure in [Before working inside your computer](#).
2. Remove the [side cover](#).

3. To remove the front bezel:
 - a. Press the latch and pry the retention tabs to release the front bezel from the system.



- b. Rotate the bezel forward and lift the front bezel away from the system.



Installing the front bezel

1. Hold the bezel and ensure that the hooks on the bezel snap into the notches on the system.
2. Rotate the bezel forward and press the front bezel until the tabs click into place.
3. Follow the procedure in [After working inside your computer](#).

Hard Disk Drive bezel

Removing HDD bezel

1. Follow the procedure in [Before working inside your computer](#).
2. Remove the [side cover](#).
3. To remove the HDD bezel:
 - a. Press the blue unlock button [1] on the edge of ODD bay.
 - b. Slide the latch [2] to the unlock position, on the front I/O bezel.
 - c. Rotate forward and lift the HDD bezel [3] away from the system.

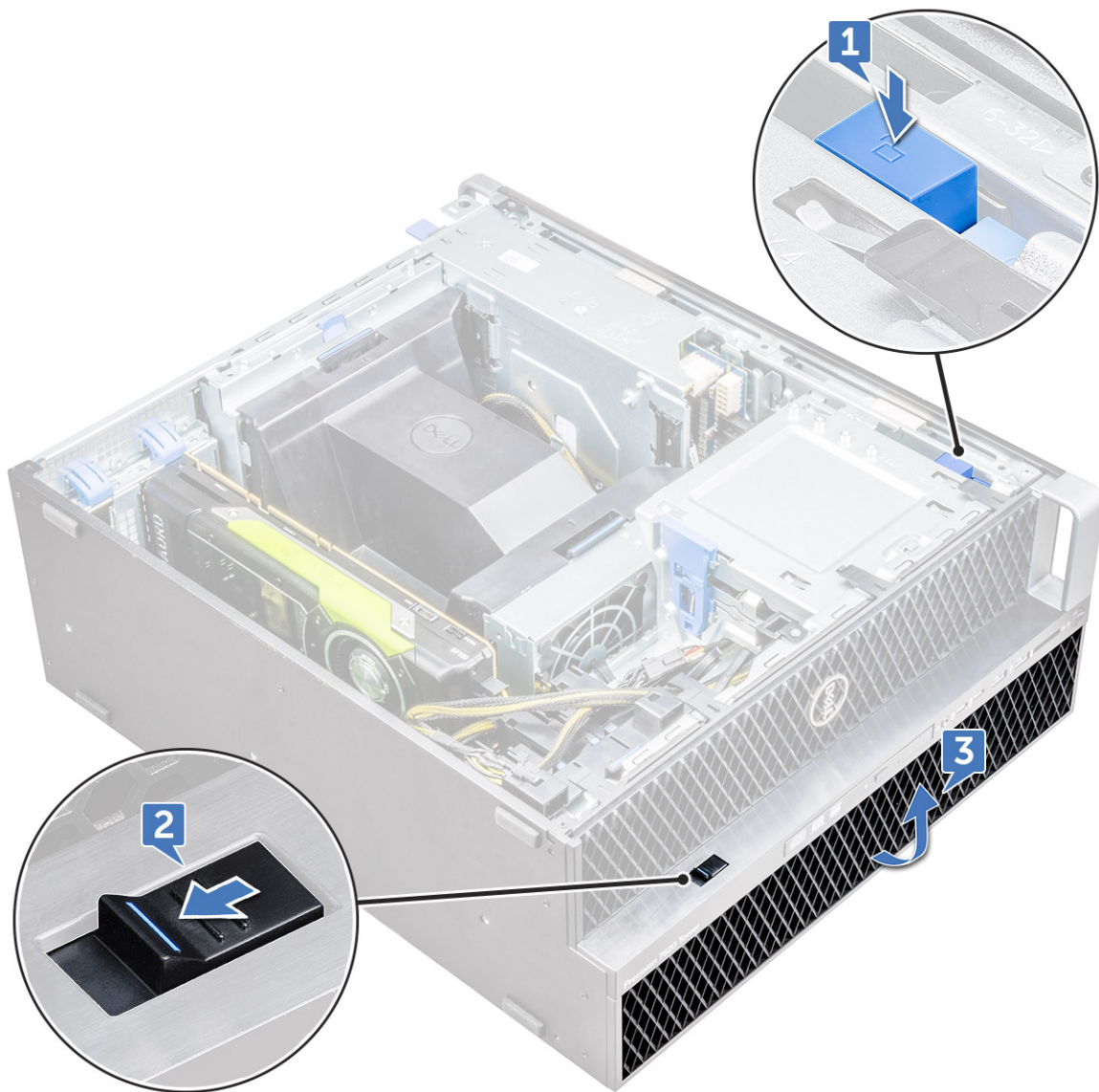

Installing HDD bezel

1. Hold the bezel and ensure that the hooks on the bezel snap into the notches on the system.
2. Press the blue lock button on the left edge of the ODD bay to secure the bezel to the system.
3. Install the [side cover](#).
4. Follow the procedure in [After working inside your computer](#).

Hard disk drive assembly

Removing the HDD carrier

1. Follow the procedure in [Before working inside your computer](#).
2. Remove the:
 - a. [side cover](#)

 **NOTE:** Do not remove the side cover, if the front I/O bezel is unlocked.

b. HDD bezel

3. To remove the HDD carrier:

- a. Press the release button [1] to unlock the latch [2].

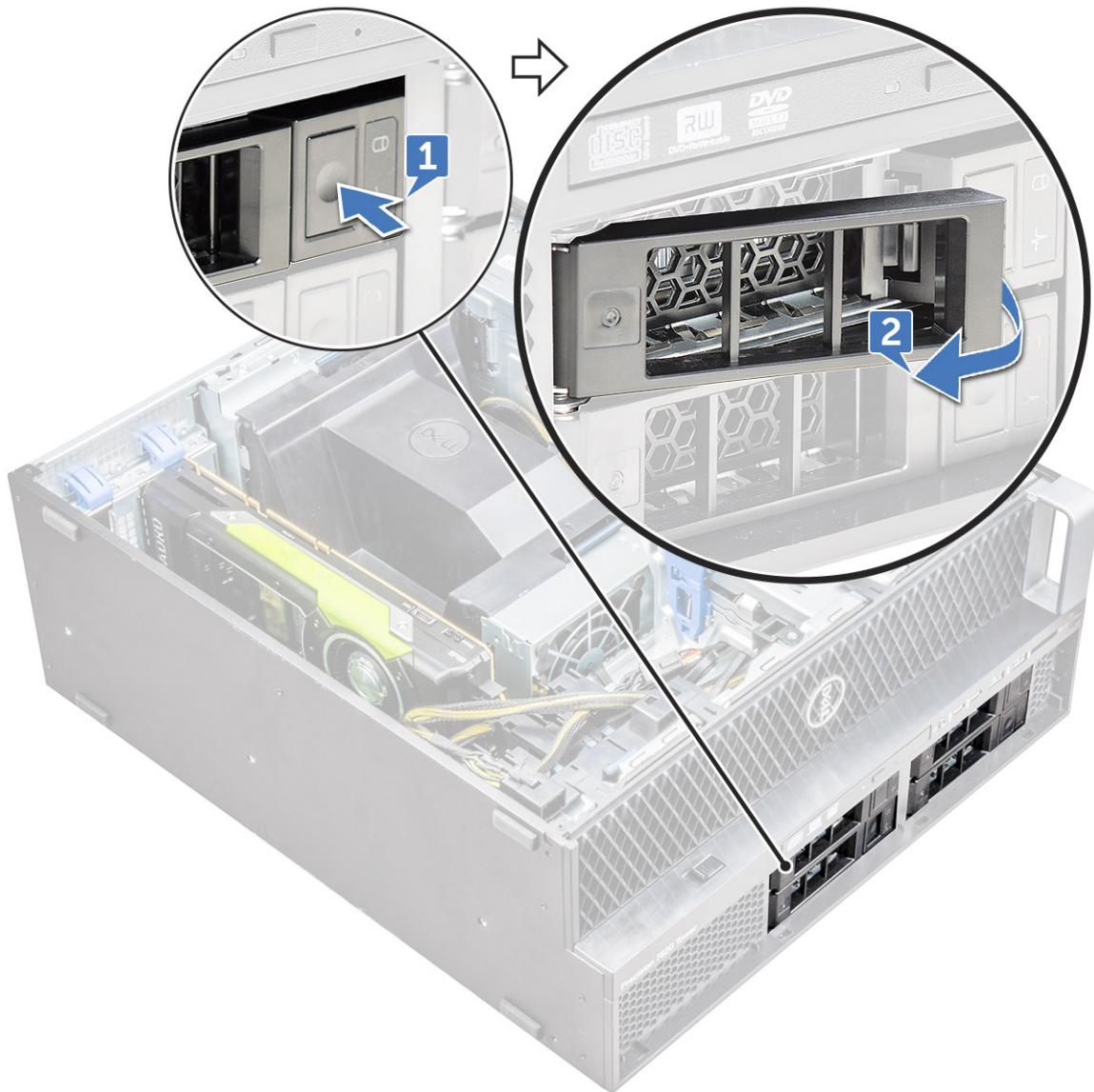

- b. Pull the latch to slide the carrier out of the HDD slot.



Installing the HDD carrier

1. Slide the carrier into the drive bay until it clicks into place.
CAUTION: Ensure that the latch is open before installing the carrier.
2. Lock the latch.
3. Install the following components:
 - a. HDD bezel
 - b. side cover
4. Follow the procedure in [After working inside your computer](#).

Removing the HDD

1. Follow the procedure in [Before working inside your computer](#).
2. Remove the following:
 - a. side cover
 - b. HDD bezel

c. HDD carrier

3. To remove the 3.5 inch HDD:

a. Expand one side of the carrier.



b. Lift the hard drive out of the carrier.



4. To remove the 2.5 inch HDD:

a. Expand two sides of the carrier.

b. Lift the hard drive out of the carrier.

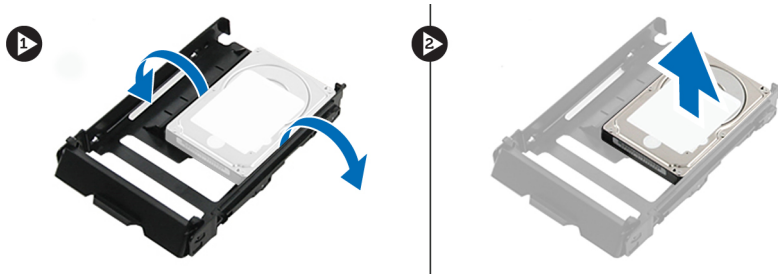

Installing the HDD

1. Insert the HDD to its slot in the HDD bracket with the connector end of the hard drive towards the back of the HDD carrier.
2. Slide the HDD carrier back into the hard drive bay.
3. Install the following:
 - a. [HDD carrier](#)
 - b. [HDD bezel](#)
 - c. [side cover](#)
4. Follow the procedure in [After working inside your computer](#)

NVMe Flexbay

Removing the NVMe Flexbay

1. Follow the procedure in [Before working inside your computer](#).
2. Remove the:
 - a. [side cover](#)

i **NOTE:** Do not remove the side cover, if the front I/O bezel is unlocked.

 - b. [HDD bezel](#)
3. To remove the NVMe flexbay :
 - a. Insert a pin into the NVMe flexbay release hole to release the NVMe flexbay.
 - b. Push the pin to disengage the lock and eject the M.2 NVMe SSD flexbay.



4. To remove the SSD carrier from the NVMe flexbay:
 - a. Press the release button to slide the M.2 SSD carrier out of the NVMe flexbay.



- b. Pull the M.2 SSD carrier out of the NVMe flexbay.



- 5. To remove the SSD from the SSD carrier:
 - a. Remove the screws on either side of the SSD.

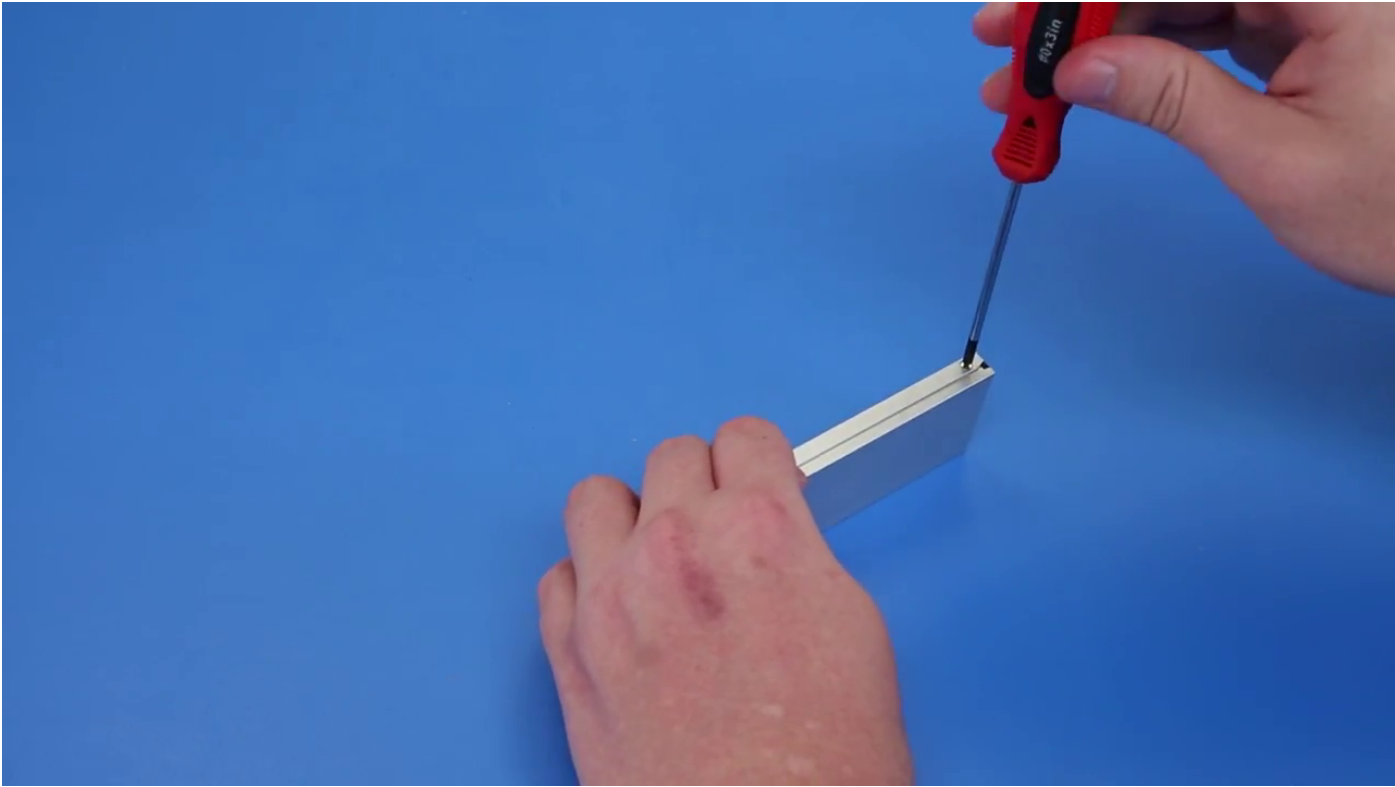

b. Remove the screw from the top of the SSD carrier.

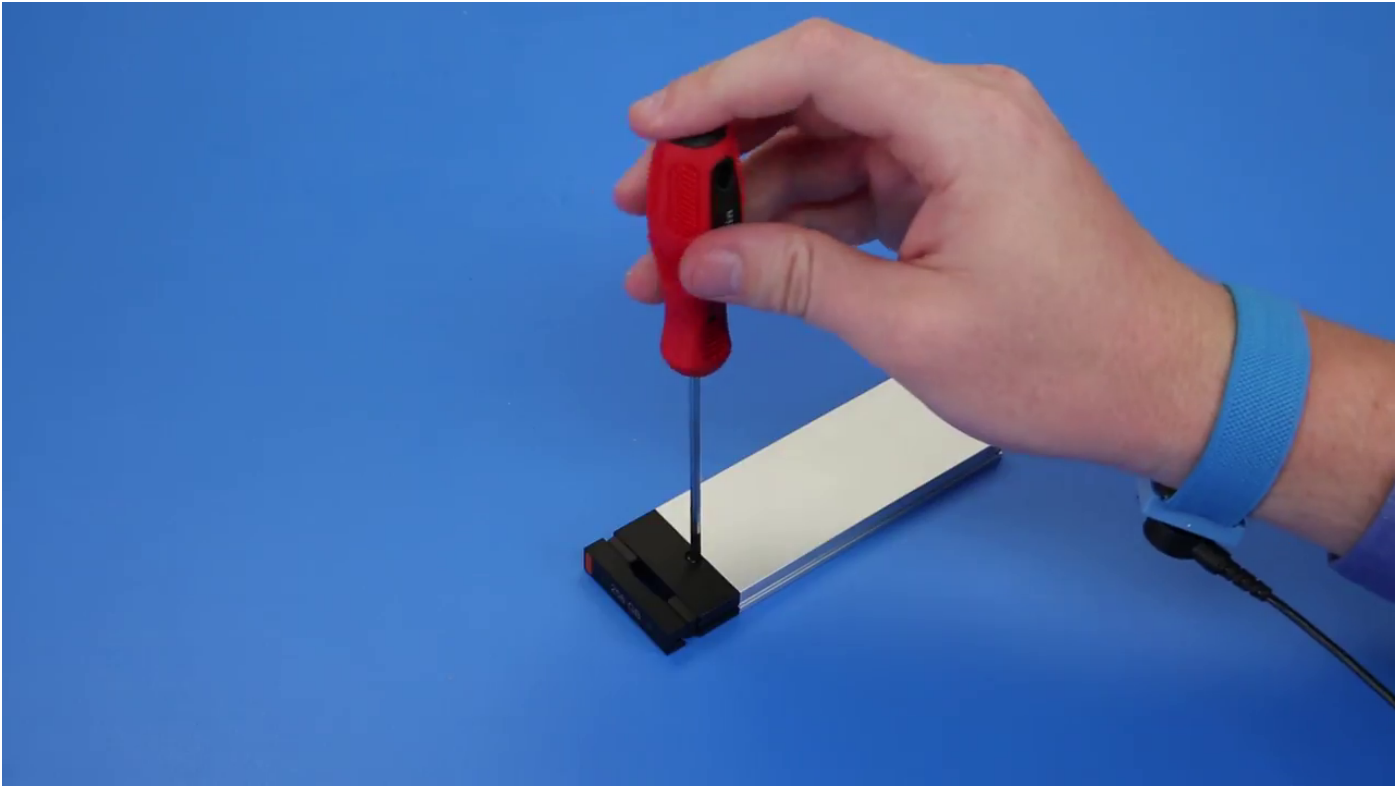

c. Slide the SSD cover from the top of the carrier.

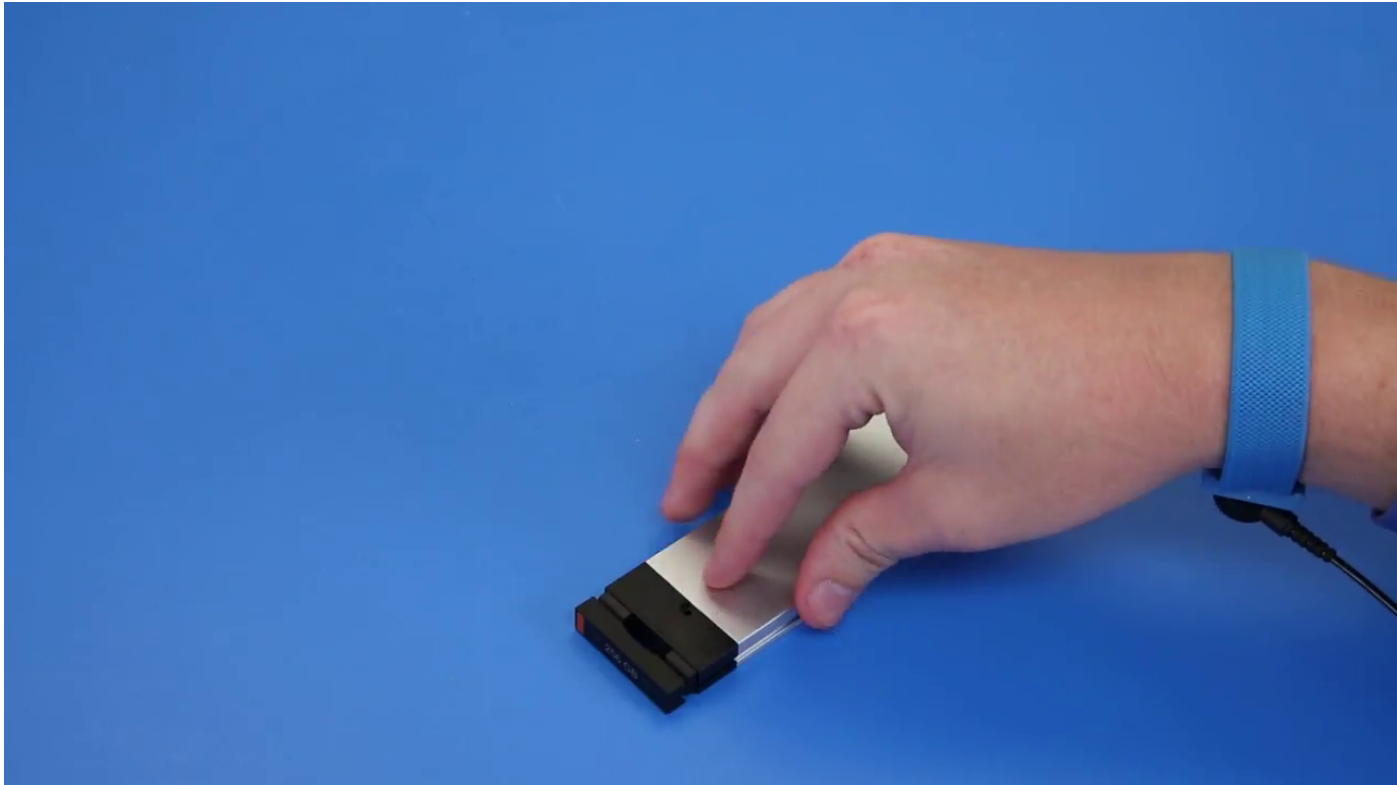

- d. Slide the SSD out of the M.2 slot on the carrier.

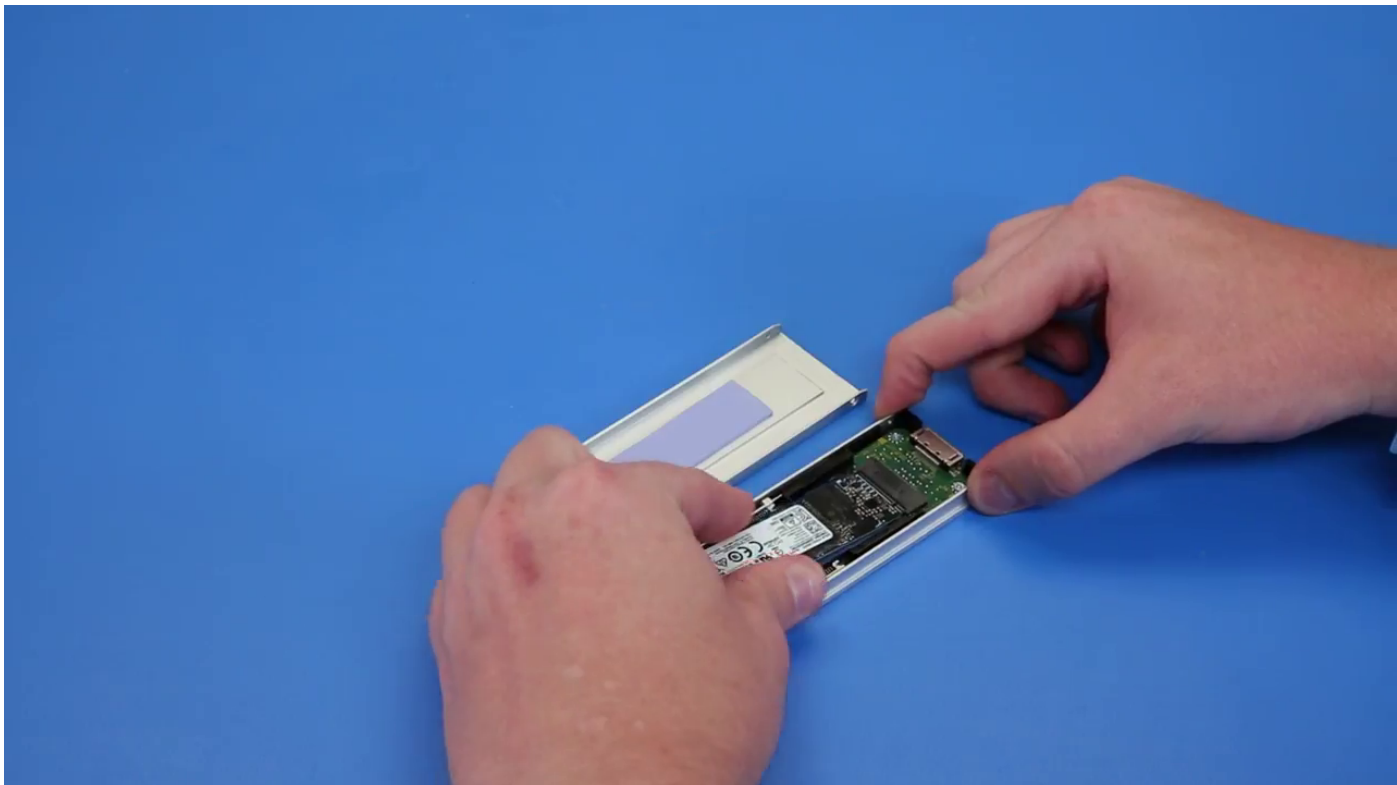

i **NOTE:** For more information on detailed parts requirement in upgrade scenarios refer to, KB Article Number: [000185631](#) and [000146243](#).

Installing the NVMe flexbay

1. To install the SSD in the carrier:

- a.  **NOTE:** NVMe Flexbay uses a SSD backplane and drop cables for installing the SSDs. HDD backplane is not compatible with the NVMe flexbay.

Remove the dummy SSD blank from the SSD carrier.

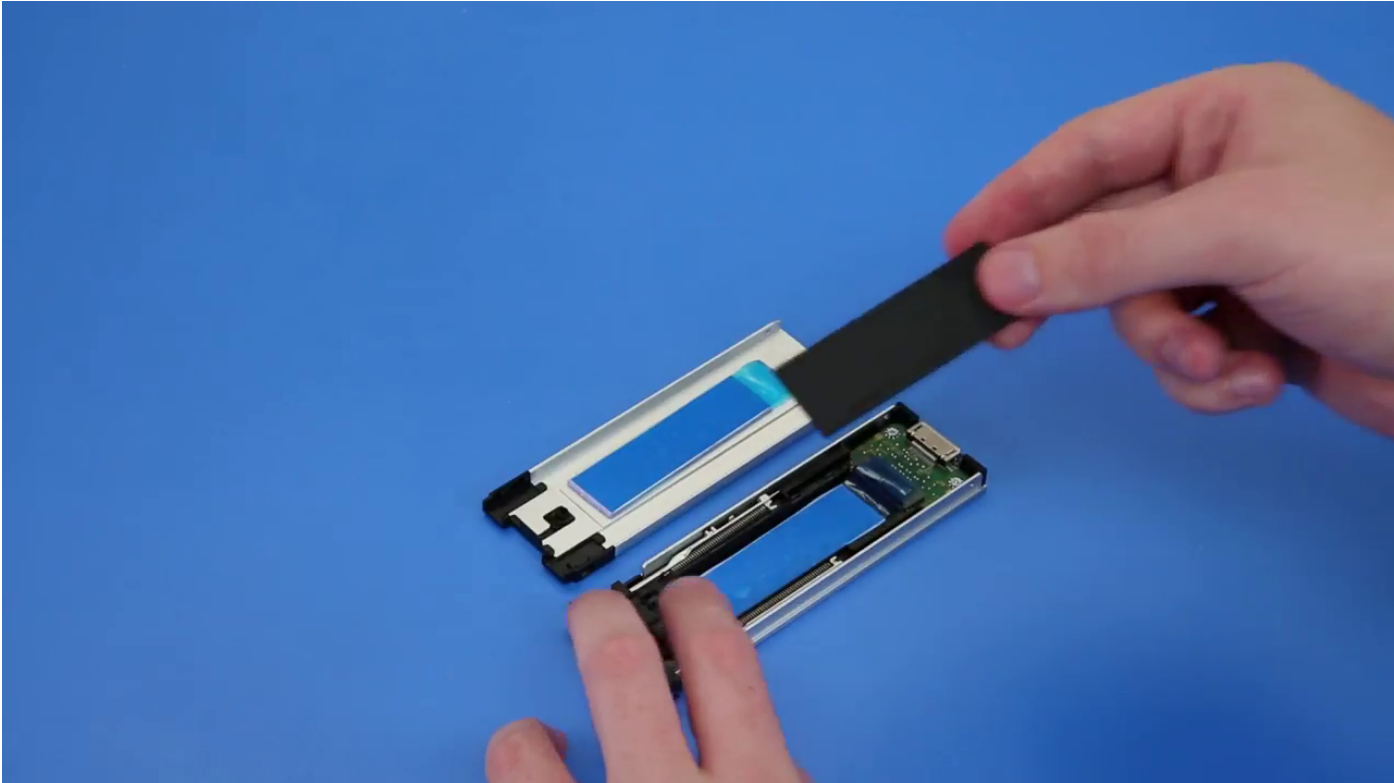

- b. Peel off the tape from the SSD carrier.

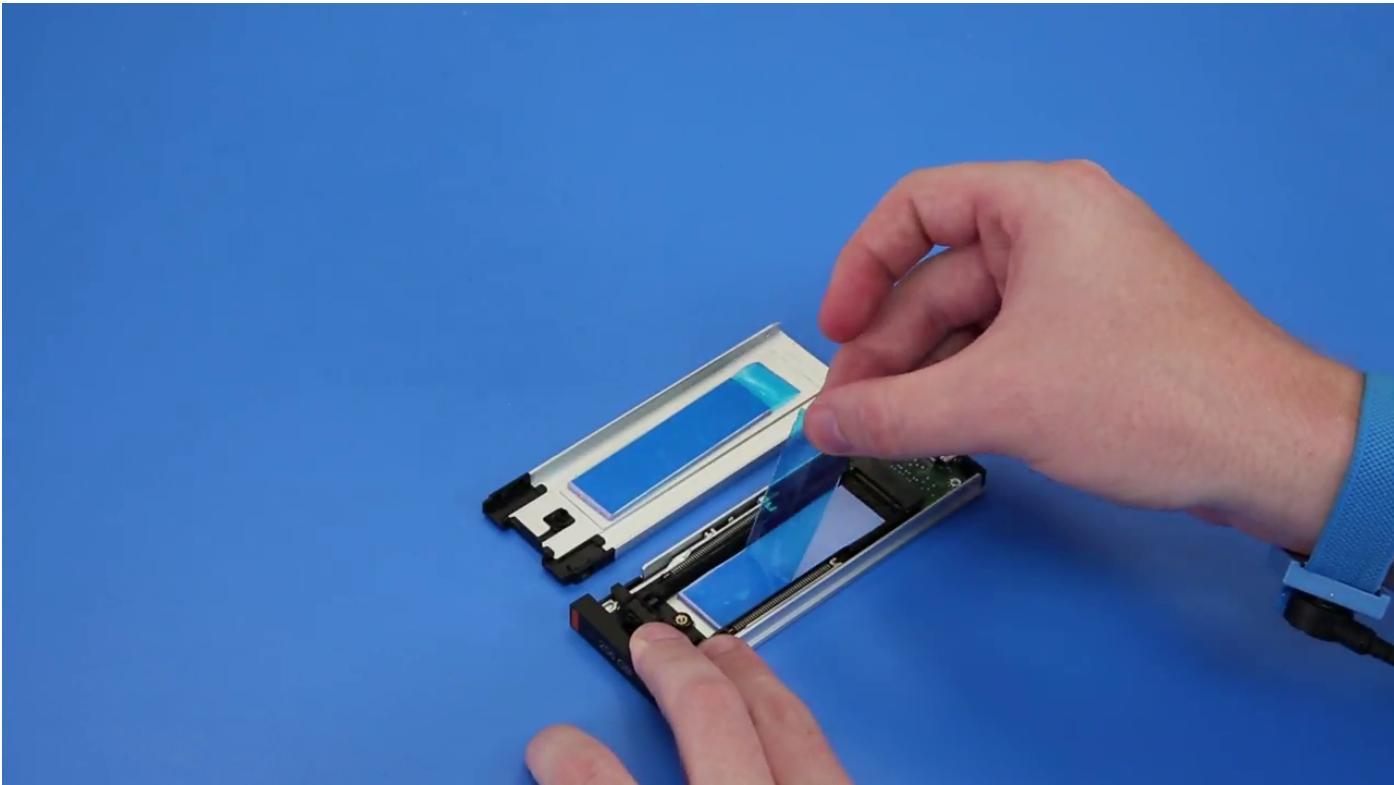

- c. Peel off the adhesive tape from the SSD carrier cover.

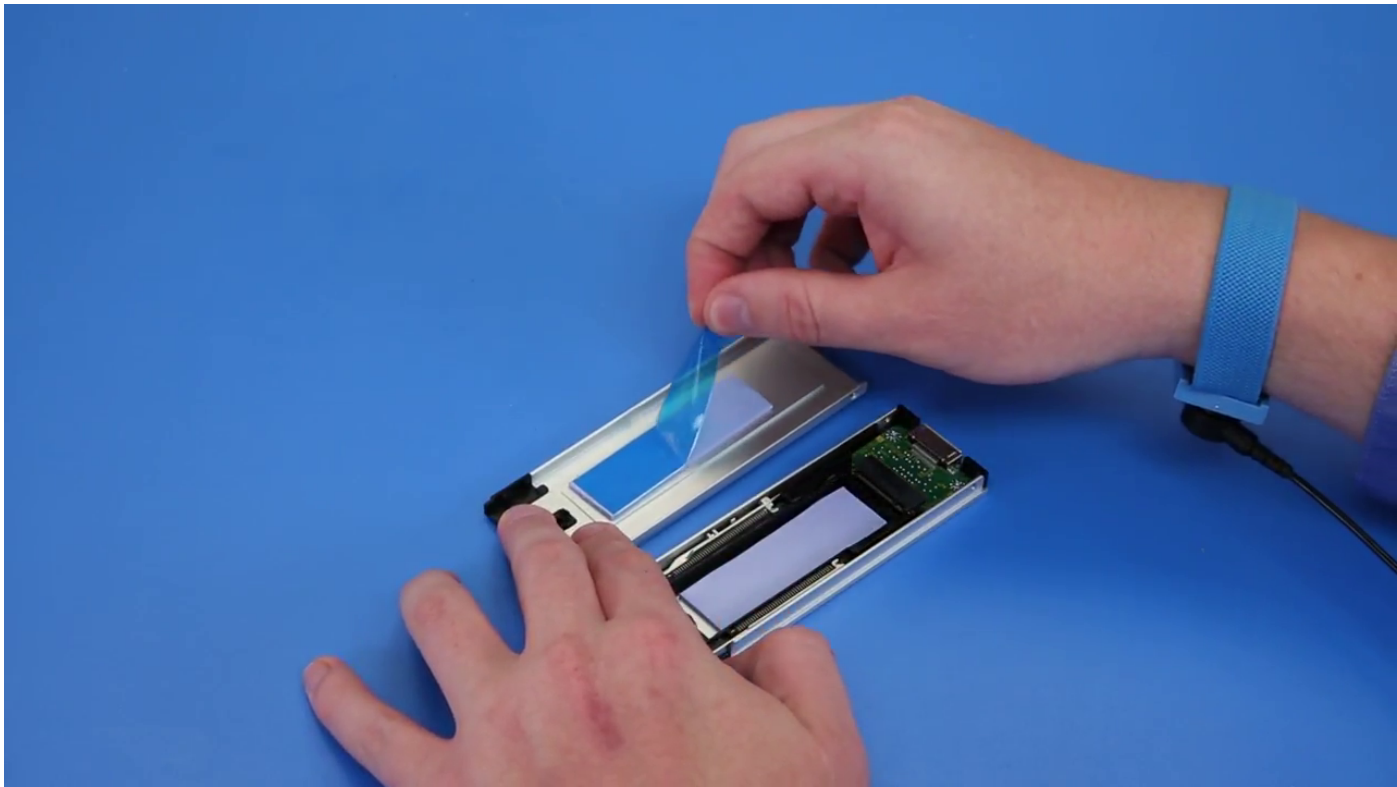

2. Install the SSD in the carrier

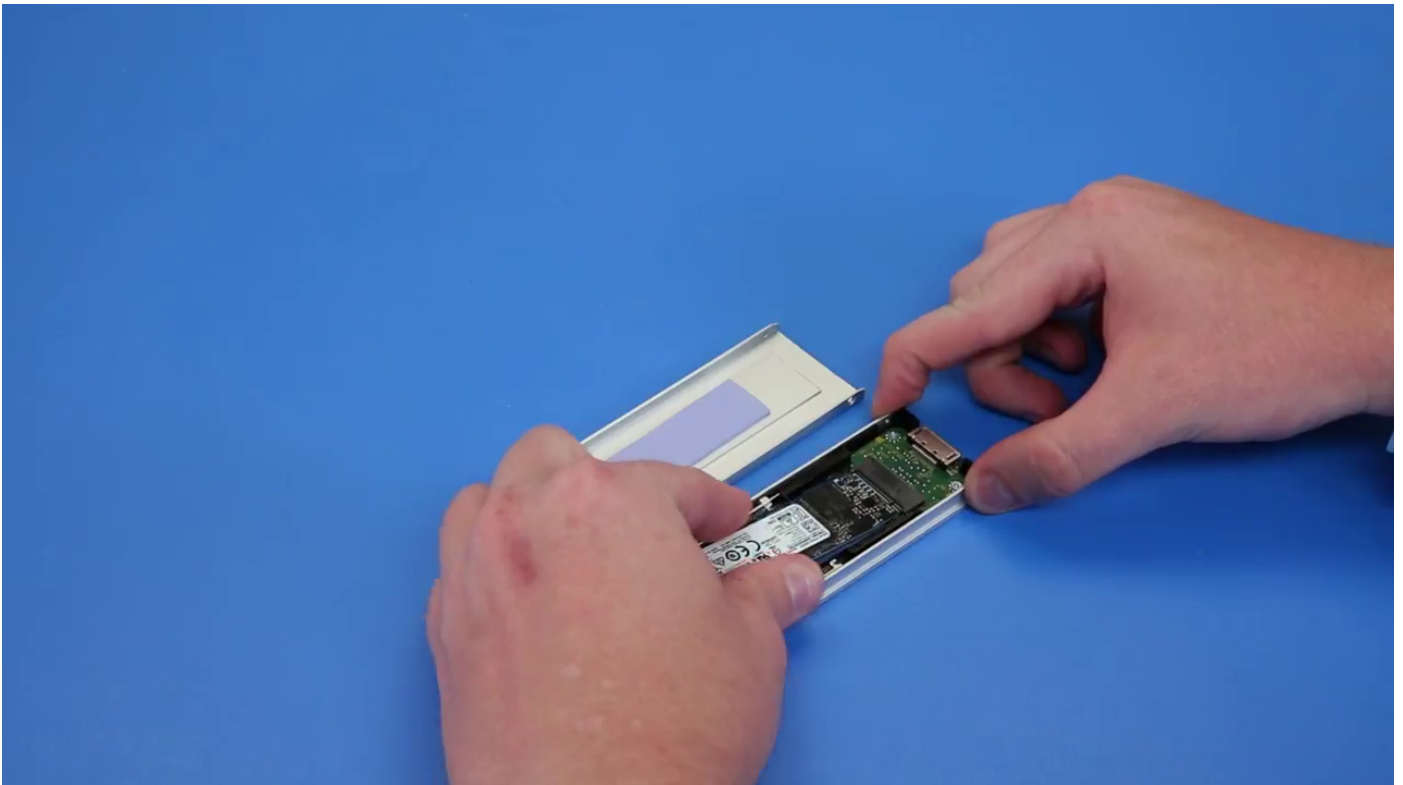

3. Replace the two side screws and the central screw.
4. To install the SSD carrier slide the carrier in the NVMe flexbay until it clicks in place.
5. Slide the carrier into the drive bay until it clicks into place.

 **CAUTION: Ensure that the latch is open before installing the carrier.**

6. Lock the latch.

7. Install the following components:
 - a. HDD bezel
 - b. side cover
8. Follow the procedure in [After working inside your computer](#).

Slim Optical Disk Drive

Removing the slim ODD

1. Follow the procedure in [Before working inside the computer](#).
2. Remove the [side cover](#).
3. To remove the slim ODD:
 - a. Remove the screw [1] that secures the slim ODD and push the slim ODD [2] out of the chassis.

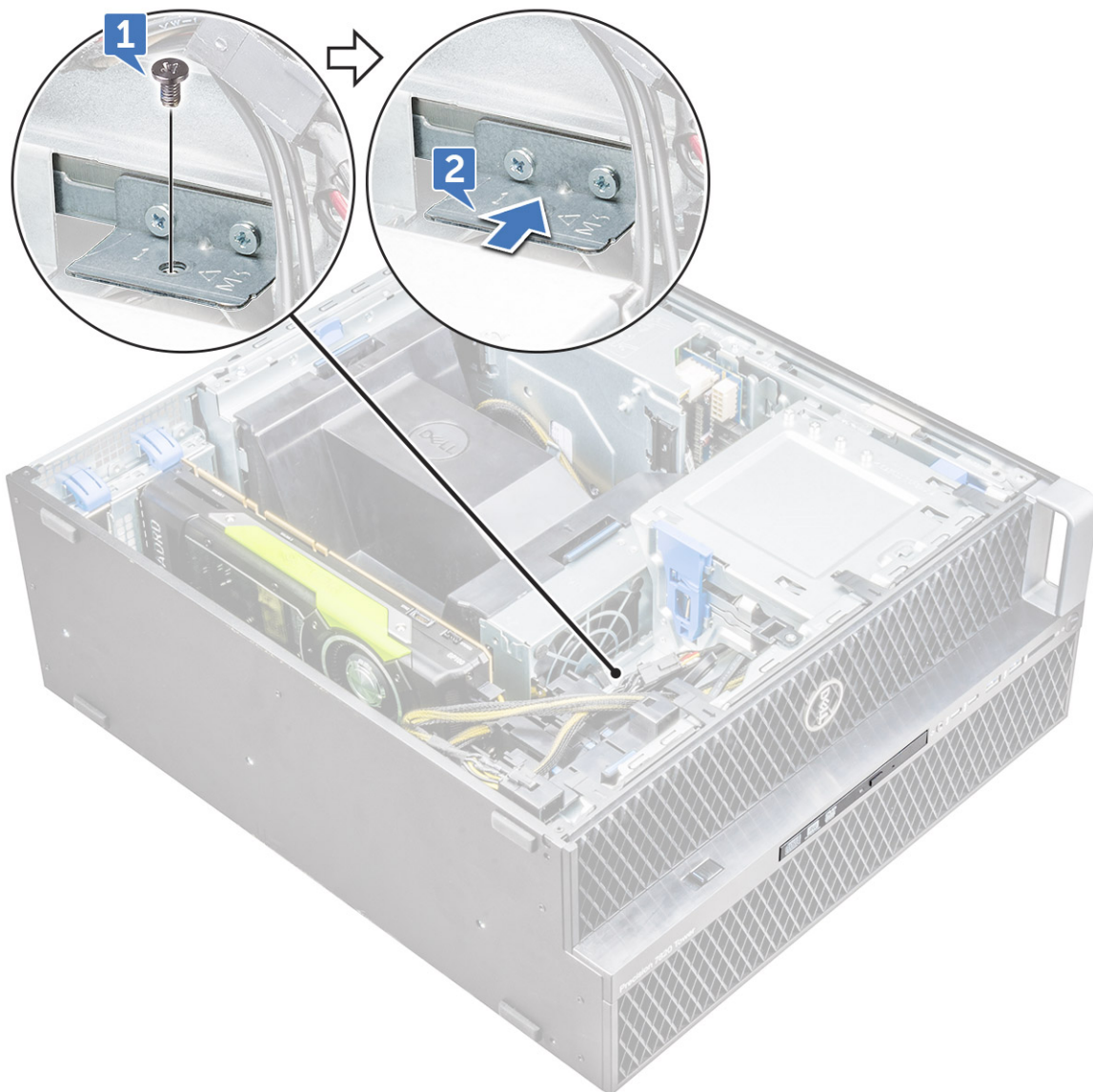

- b. Slide the slim ODD out of the system.



Installing the slim ODD

1. Slide the slim ODD into the slot on the chassis.
2. Tighten the screw to secure the slim ODD to the chassis.
3. Install the [side cover](#).
4. Follow the procedure in [After working inside your computer](#).

Front input and output bezel

Removing front input and output bezel

1. Follow the procedure in [Before working inside your computer](#).
2. Remove the:
 - a. [side cover](#)
 - b. [front bezel](#)
3. To remove the front input and output(I/O) bezel:
 - a. Pry the four retention tabs[1] from the chassis and push the bezel out from the chassis[2].

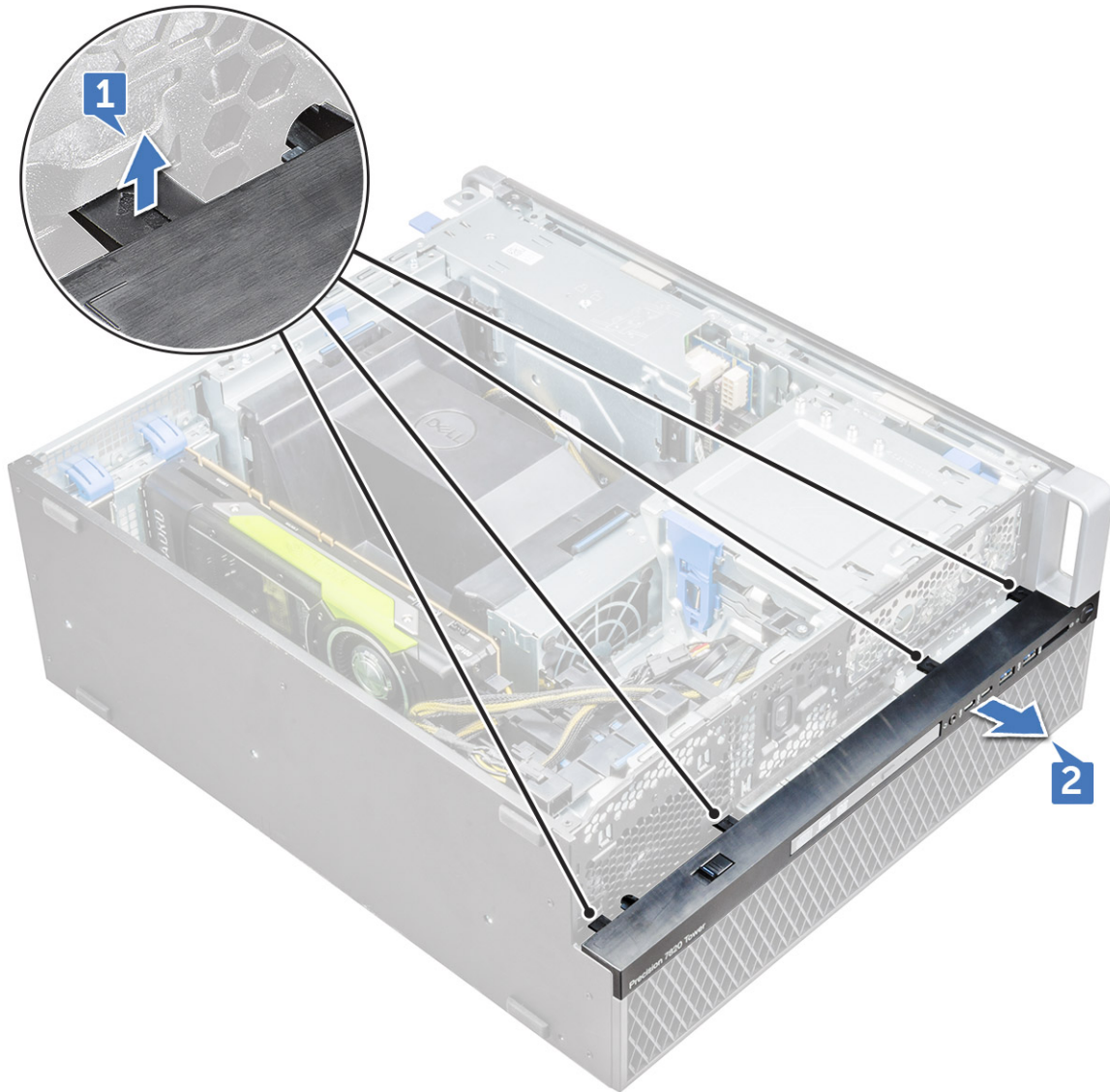

b. Lift the bezel from the chassis.

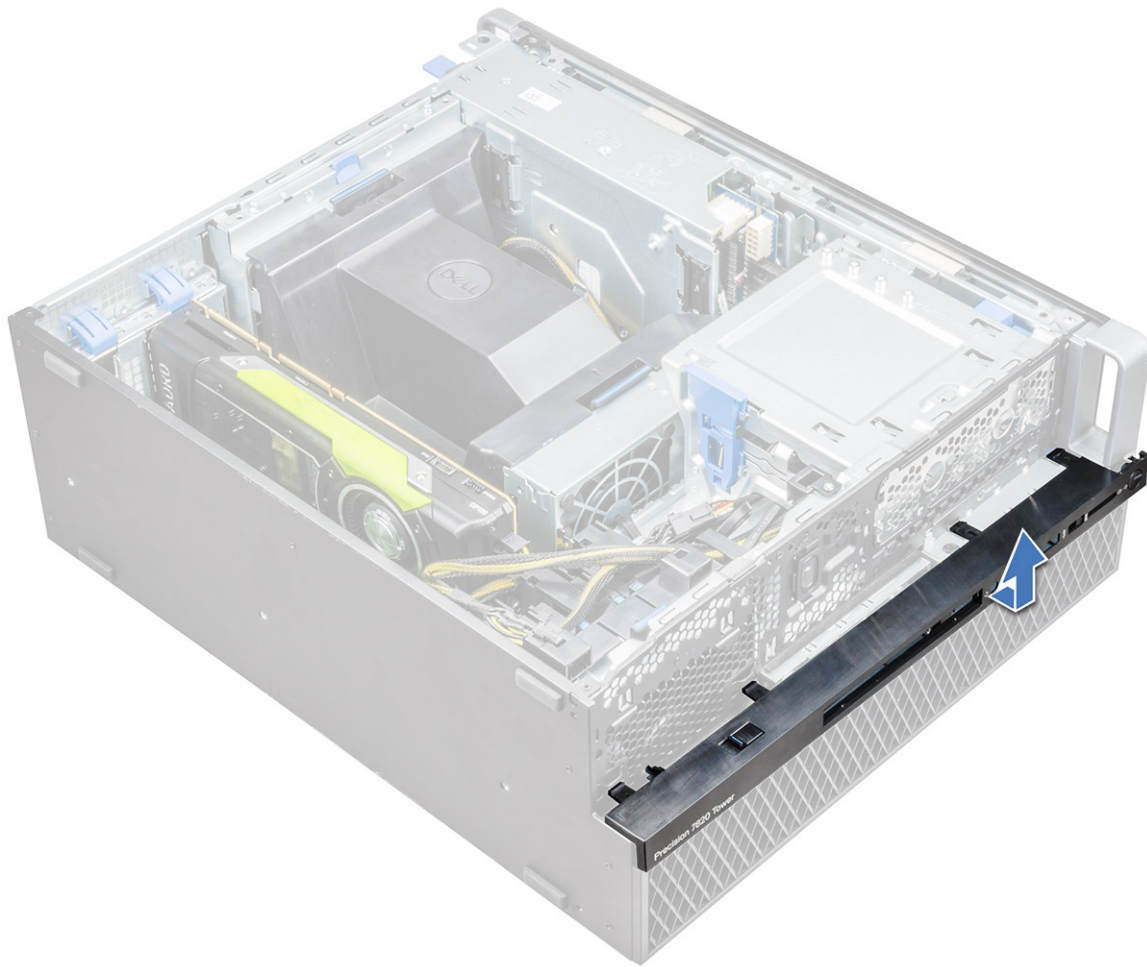

Installing front input and output bezel

1. Hold the input and output(I/O) bezel and ensure that the hooks on the bezel snap into the notches on the system.
2. Press the retention tabs and secure them to the chassis.
3. Install the :
 - a. front bezel
 - b. side cover
4. Follow the procedure in [After working inside your computer](#).

5.25 inch ODD bracket

Removing the 5.25 ODD bracket

1. Follow the procedure in [Before working inside your computer](#).
2. Remove the:
 - a. side cover
 - b. front bezel
3. To remove the ODD bracket:
 - a. Remove the ODD filler from the chassis.



- b. Remove the five screws[1,2] that secure the bracket to the chassis.

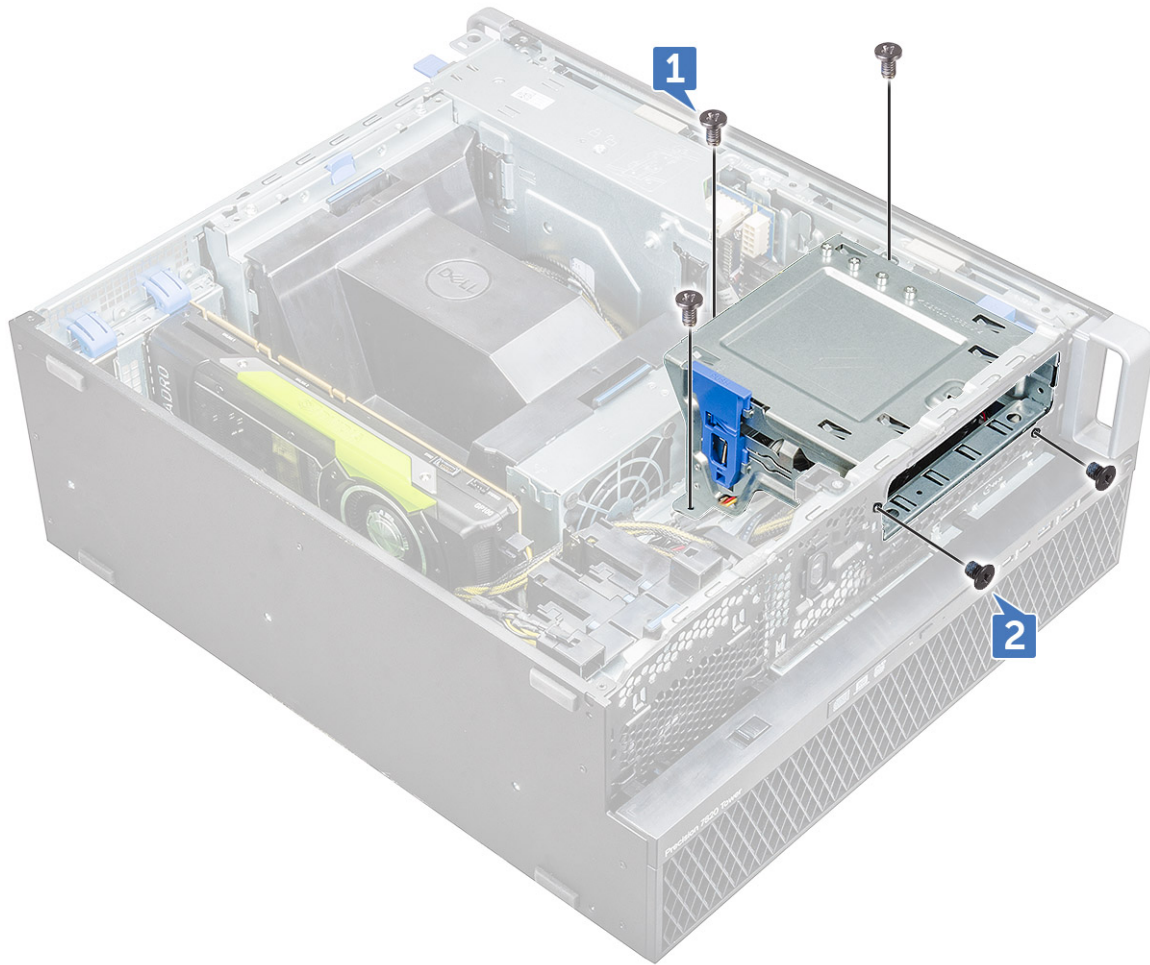

c. Slide the ODD bracket toward the rear of the system and lift it away from the chassis.



Installing the 5.25 ODD bay

1. Place the ODD bracket into the system slot.
2. Replace the (6-32 X 6.0mm) screws.
3. Place the ODD filler back into the slot.
4. Install the:
 - a. front bezel
 - b. side cover
5. Follow the procedure in [After working inside your computer](#)

Front input and output panel

Removing front input and output panel

1. Follow the procedure in [Before working inside your computer](#).
2. Remove the:
 - a. side cover
 - b. front bezel
 - c. front input and output bezel
 - d. 5.25 inch ODD bracket
3. To remove the front input and output(I/O) panel:

- a. Disconnect the intrusion switch cable [1], USB 3.1 cable [2], front I/O power cable [3], USB 3.1 cable [4], Speaker cable [5], Audio cable [6]

NOTE: Do not pull the connector by the cable wires. Instead, disconnect the cable by pulling the connector end. Pulling the cable wires may loosen them from the connector.

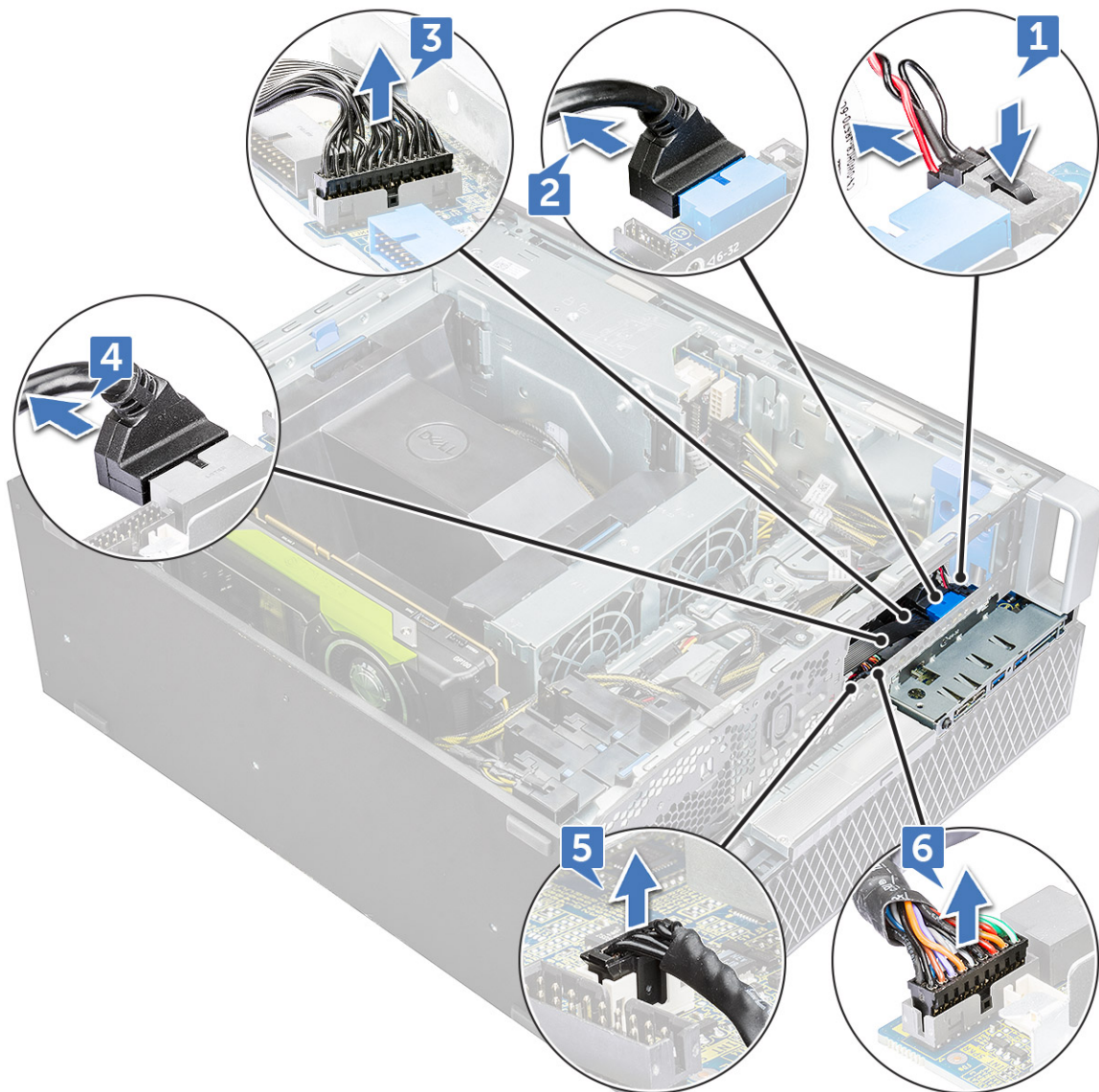

- b. Remove the screw that secures the front I/O panel to the chassis.

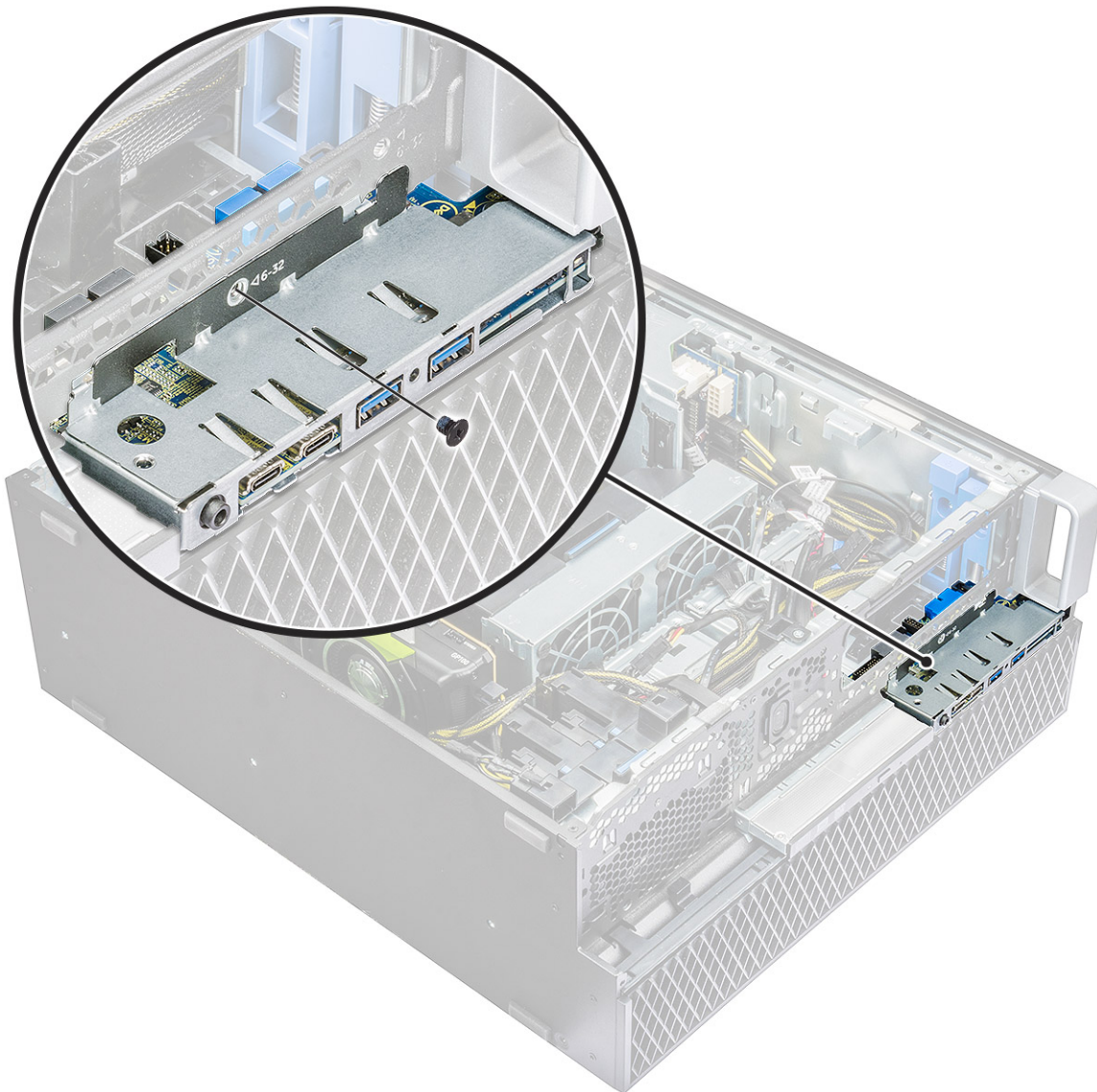

c. Slide the I/O panel out of the chassis.

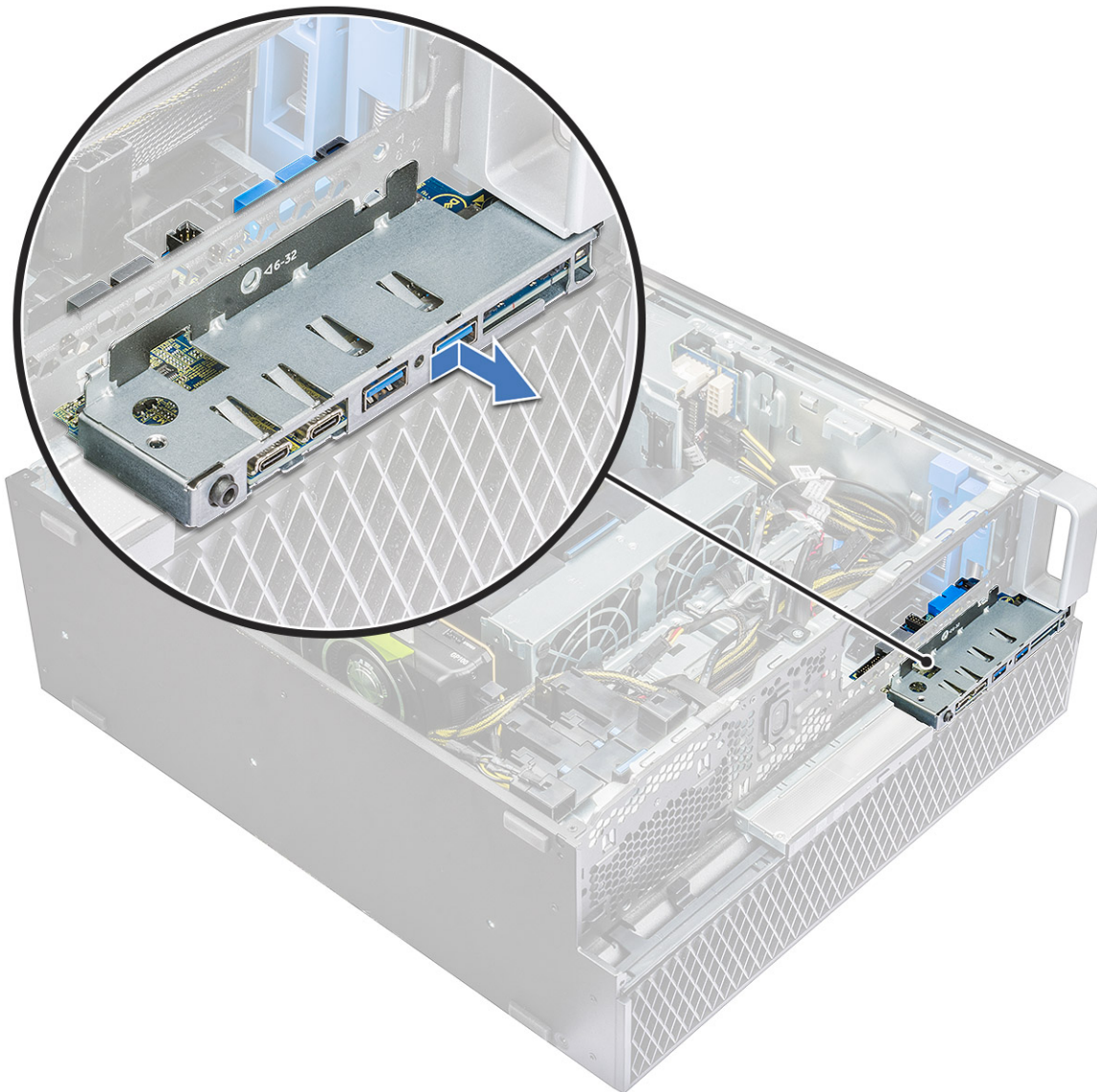

Installing front input and output panel

1. Insert the input and output(I/O) panel onto its slot in the system.
2. Slide the panel to secure the hooks into the chassis hole.
3. Tighten the screw to secure the front I/O panel to the chassis.
4. Connect the following cables:
 - intrusion switch cable
 - USB 3.1 cable
 - front I/O power cable
 - front I/O power cable
 - USB 3.1 cable
 - speaker cable
 - audio cable
5. Install the:
 - a. [front input and output bezel](#)
 - b. [5.25 inch ODD bracket](#)
 - c. [front bezel](#)
 - d. [side cover](#)

6. Follow the procedure in [After working inside your computer](#).

Input and output panel bracket

Removing input and output panel bracket

1. Follow the procedure in [Before working inside your computer](#).
2. Remove the:
 - a. [side cover](#)
 - b. [front bezel](#)
 - c. [front input and output bezel](#)
 - d. [5.25 inch ODD bracket](#)
 - e. [front input and output panel](#)
3. To remove the input and output(I/O) panel bracket:
 - a. Remove the two screws.

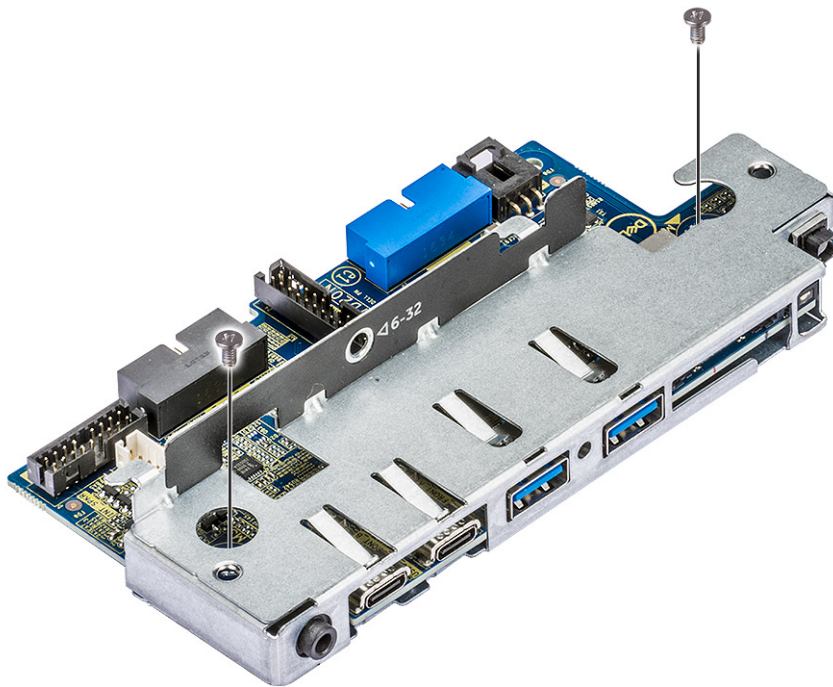

- b. Slide the I/O module out of the bracket.

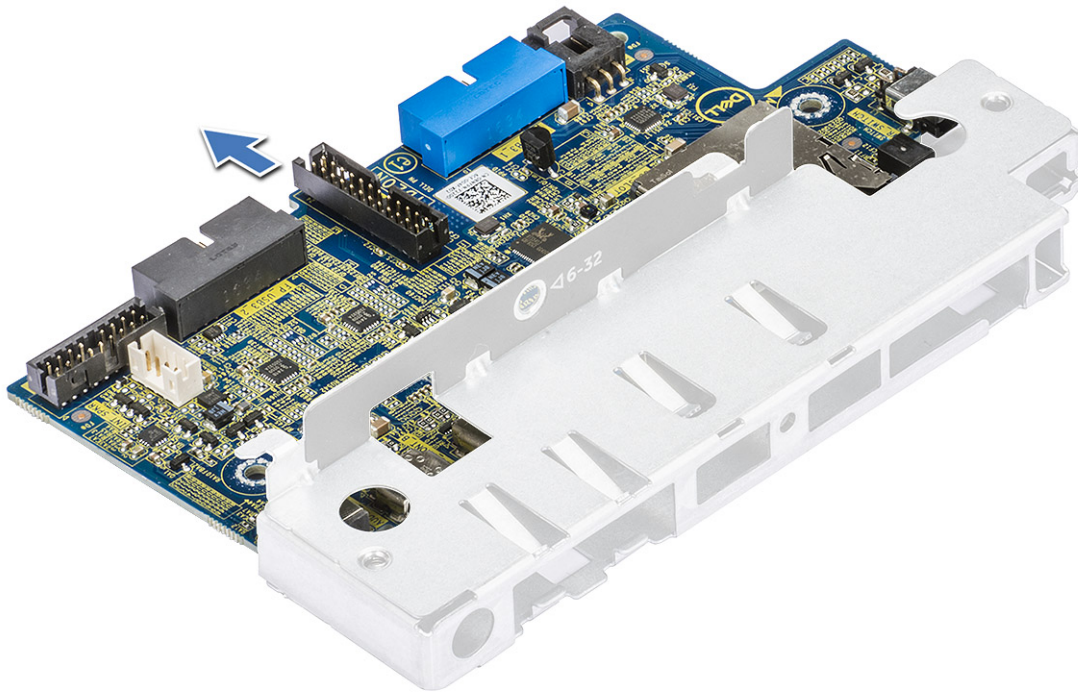

Installing input and output panel bracket

1. Insert the input and output(I/O) panel into the metal bracket.
2. Replace the screws to secure the I/O panel bracket to the I/O panel.
3. Install the:
 - a. front input and output panel
 - b. front input and output bezel
 - c. 5.25 inch ODD bracket
 - d. front bezel
 - e. side cover
4. Follow the procedure in [After working inside your computer.](#)

VROC module

Removing the VROC module

Plug-out the VROC module from the system board in the upward direction.

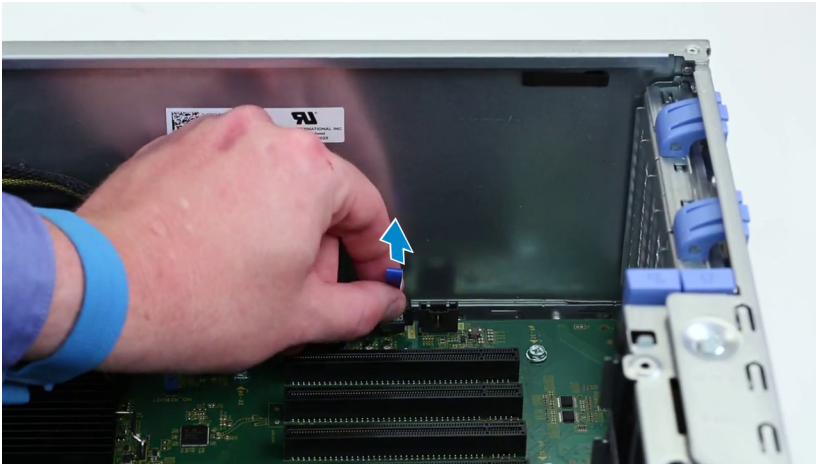

Installing the VROC module

Plug-in the VROC module to the system board.

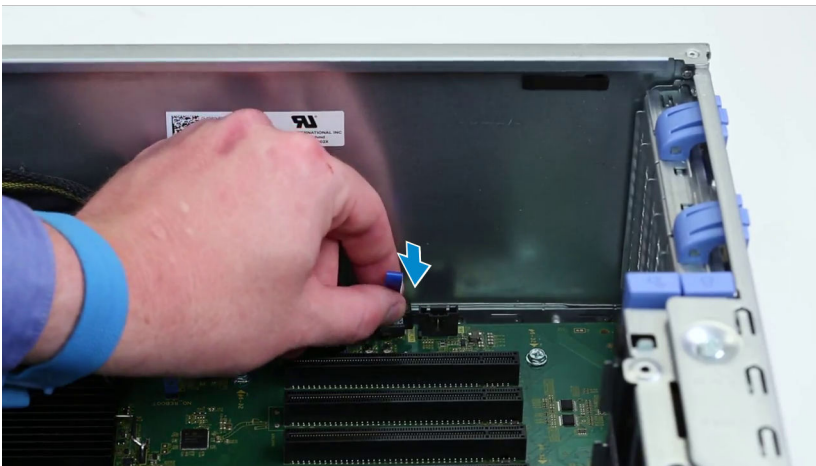

Intrusion switch

Removing the Intrusion switch

1. Follow the procedure in [Before working inside your computer](#).
2. Remove the:
 - a. [side cover](#)
 - b. [front bezel](#)
 - c. [5.25 inch ODD bracket](#)
3. To remove the intrusion switch:
 - a. Disconnect the intrusion cable [1] from the I/O module.
 - b. Remove the screw [2] that secures the intrusion switch to the chassis.
 - c. Lift the intrusion switch and remove it from the chassis.

i **NOTE:** The system will not power on without the intrusion switch installed.

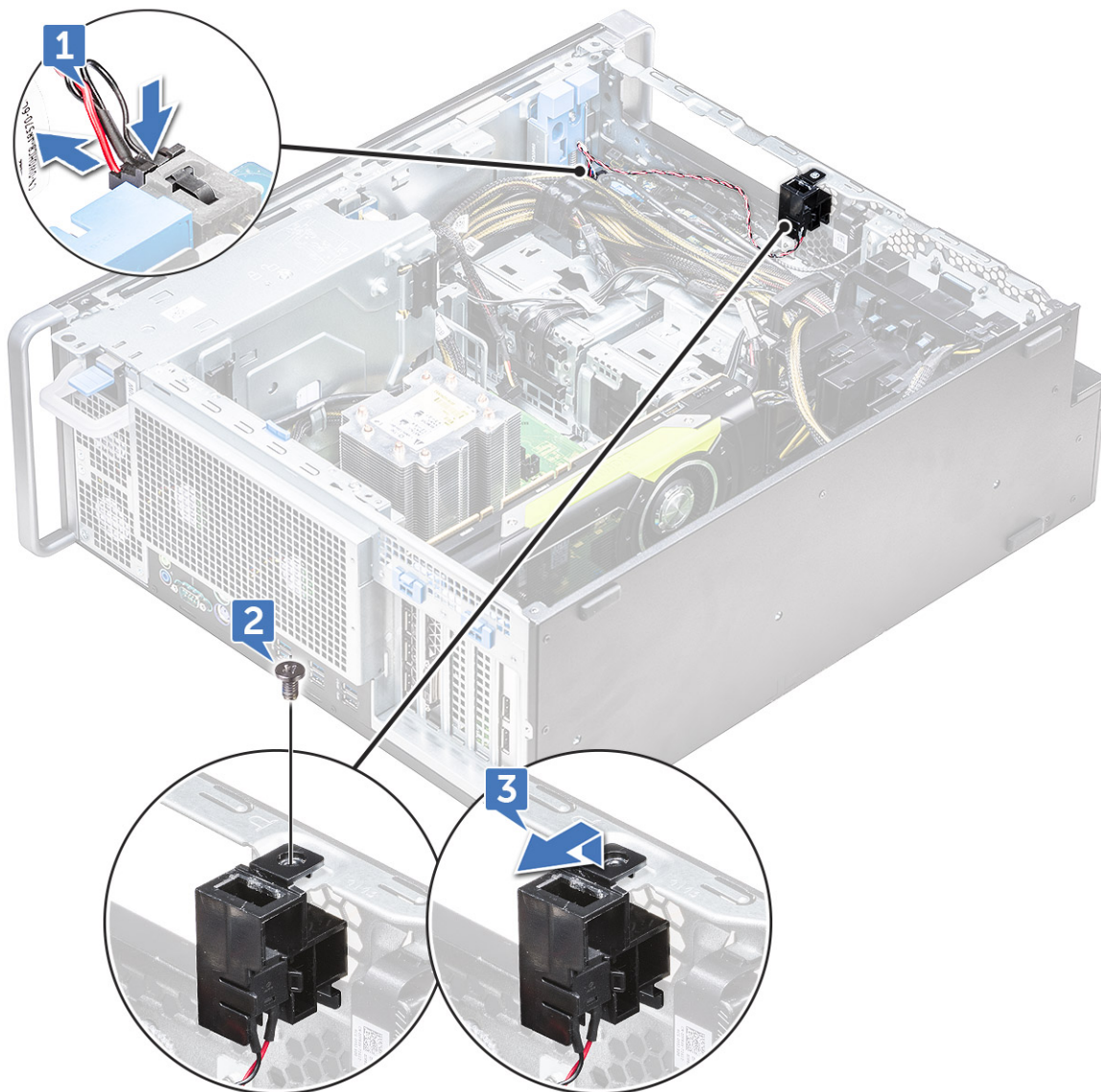

Installing the intrusion switch

1. Place the intrusion switch into the slot in the system chassis.
2. Replace the screw and secure the switch to the chassis.
3. Connect the cable to the system board.
4. Install the:
 - a. 5.25 inch ODD bracket
 - b. front bezel
 - c. side cover
5. Follow the procedure in [After working inside your computer](#).

Internal chassis speaker

Removing the internal chassis speaker

1. Follow the procedure in [Before working inside your computer](#).
2. Remove the: .

- a. side cover
 - b. front bezel
 - c. 5.25 inch ODD bracket
3. To remove the internal chassis speaker:
- a. Disconnect the speaker cable [1] from the front I/O module.
 - b. Press the speaker securing tabs [2], then pull to release it from the system.
 - c. Gently push the speaker [3] with its cable out of the system.

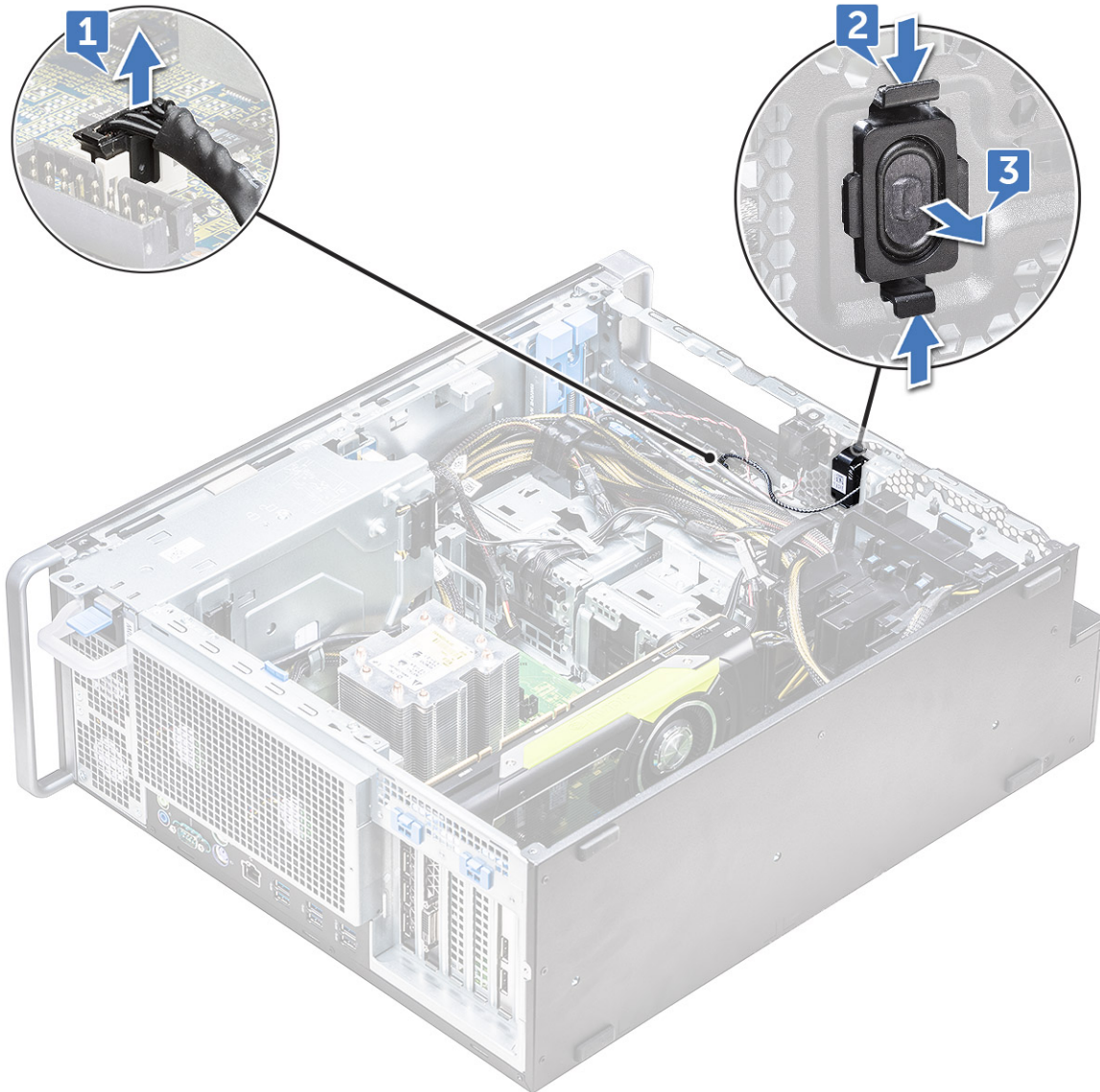

Installing the internal chassis speaker

1. Press and hold the tabs on either side of the intrusion speaker, and slide the speaker module into the slot to secure it to the system.
2. Connect the internal chassis speaker cable to the connector on the system chassis.
3. Install the:
 - a. 5.25 inch ODD bracket
 - b. front bezel
 - c. side cover
4. Follow the procedure in [After working inside your computer](#)

Air shroud

Removing the air shroud

1. Follow the procedure in [Before working inside your computer](#).
2. Remove the [side cover](#)
3. To remove the air shroud:
 - a. Holding the shroud at both the ends, press the tabs[1] and then lift the shroud[2] from the system.

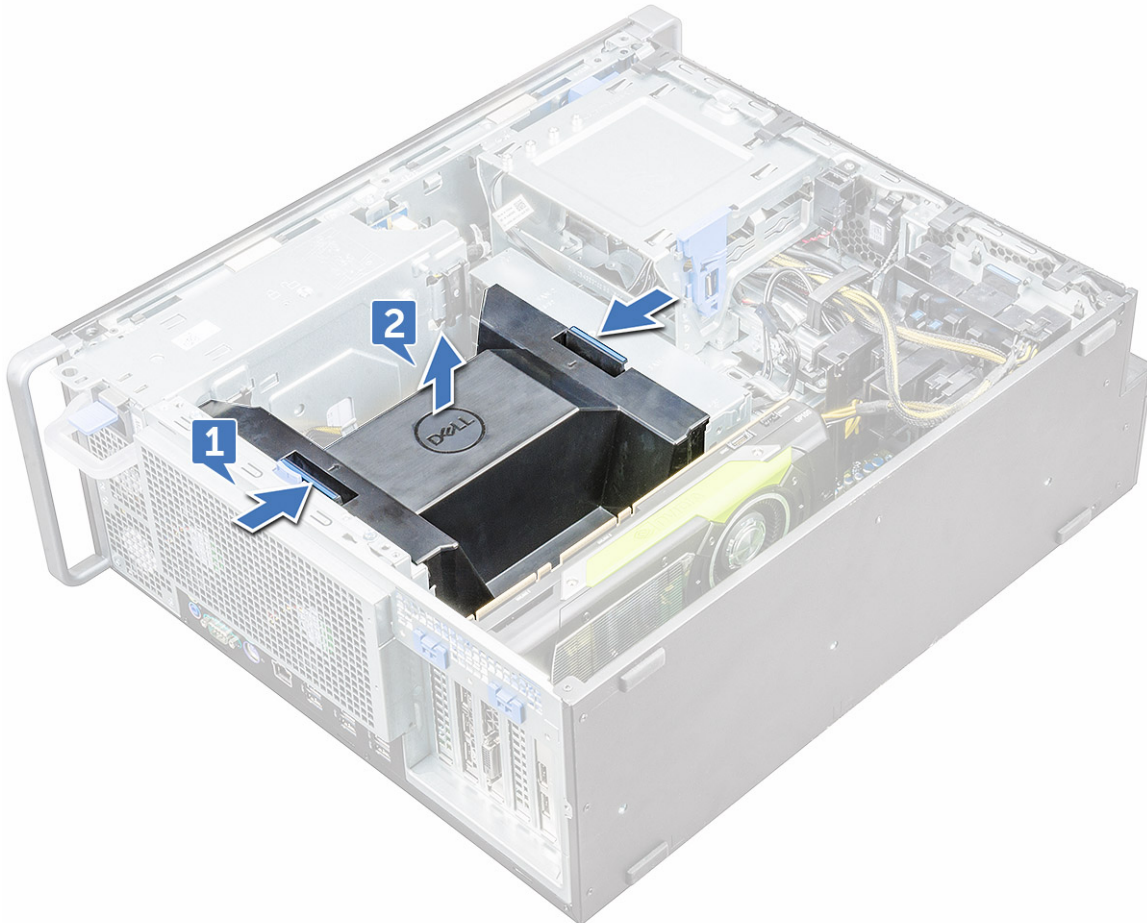

Installing the air shroud

1. Place the shroud into its position and make sure that the tab fits into the system.
2. Align the shroud to its locking tab.
3. Press down the shroud until it clicks into place.
4. Install the [side cover](#).
5. Follow the procedure in [After working inside your computer](#).

Memory

Removing the memory module

1. Follow the procedure in [Before working inside your computer](#).
2. Remove the following:
 - a. [side cover](#)
 - b. [air shroud](#)
3. Press the memory module retention tabs on each side of the memory module.
4. Lift the memory module out of the memory slot on the system board.

 **WARNING:** Rotating the memory module out of the slot will cause damage to the memory module. Ensure to pull it straight out of the memory module slot.

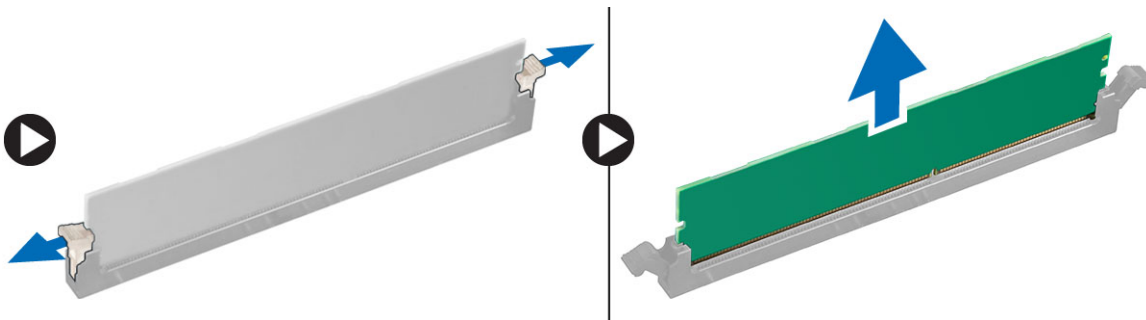

Installing the memory module

1. Align the notch on the memory module with the tab on the memory module connector.
2. Insert the memory module into the memory module slot.
3. Press the memory module firmly until the retention tabs click into place.

 **NOTE:** Do not pull the retention levers up. Always press down firmly on the module until the levers lock into place unassisted.

4. Install the:
 - a. [air shroud](#)
 - b. [side cover](#)
5. Follow the procedure in [After working inside your computer](#)

Graphical processing unit(GPU)

Removing the GPU

1. Follow the procedure in [Before working inside your computer](#).
2. Remove the [side cover](#).
3. To remove the GPU:
 - a. Disconnect the power cable [1] from the GPU card.
 **NOTE:** Not all GPU cards will have power cable, may not apply to all systems.
 - b. Press and rotate the blue clips backward [2], to unlock the filler bracket.

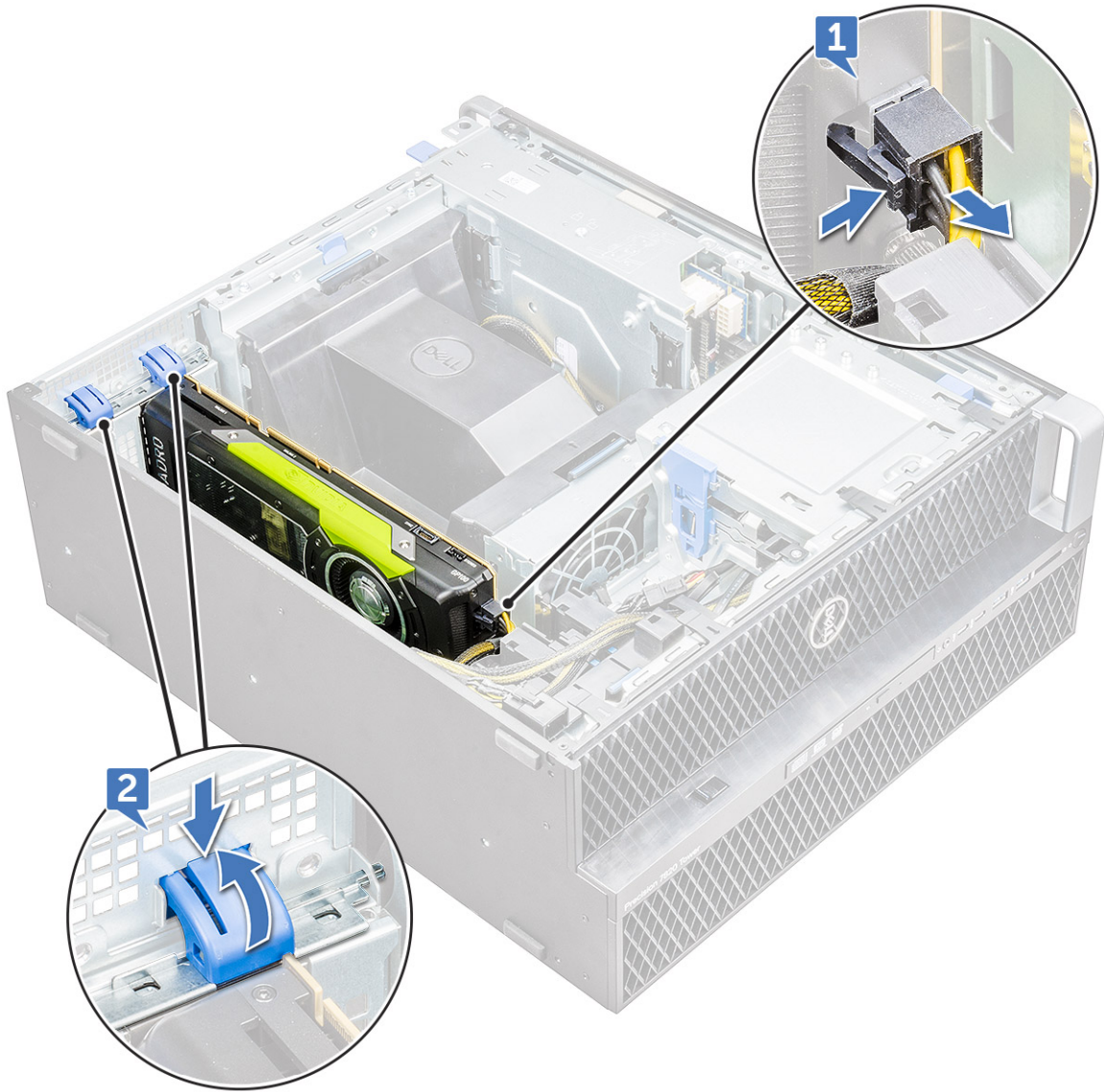

c. Lift the GPU from the PCIe slot on the system board.



Installing the GPU

1. Align and place the GPU to the PCIe slot on the system board.
2. Press it down so that it is securely seated on the slot.
3. Connect the power cable to the GPU.
4. Lock both the blue clips forward on the filler bracket to secure the GPU to the system board.
5. Install the [side cover](#).
6. Follow the procedure in [After working inside your computer](#).

Coin cell battery

Removing the coin cell battery

1. Follow the procedure in [Before working inside your computer](#).
2. Remove the:
 - a. [side cover](#)
 - b. [graphical processing unit\(GPU\)](#)
3. To remove the coin cell battery:
 - a. Press the release latch [1] away from the battery to allow the battery to pop-up from the socket [2].

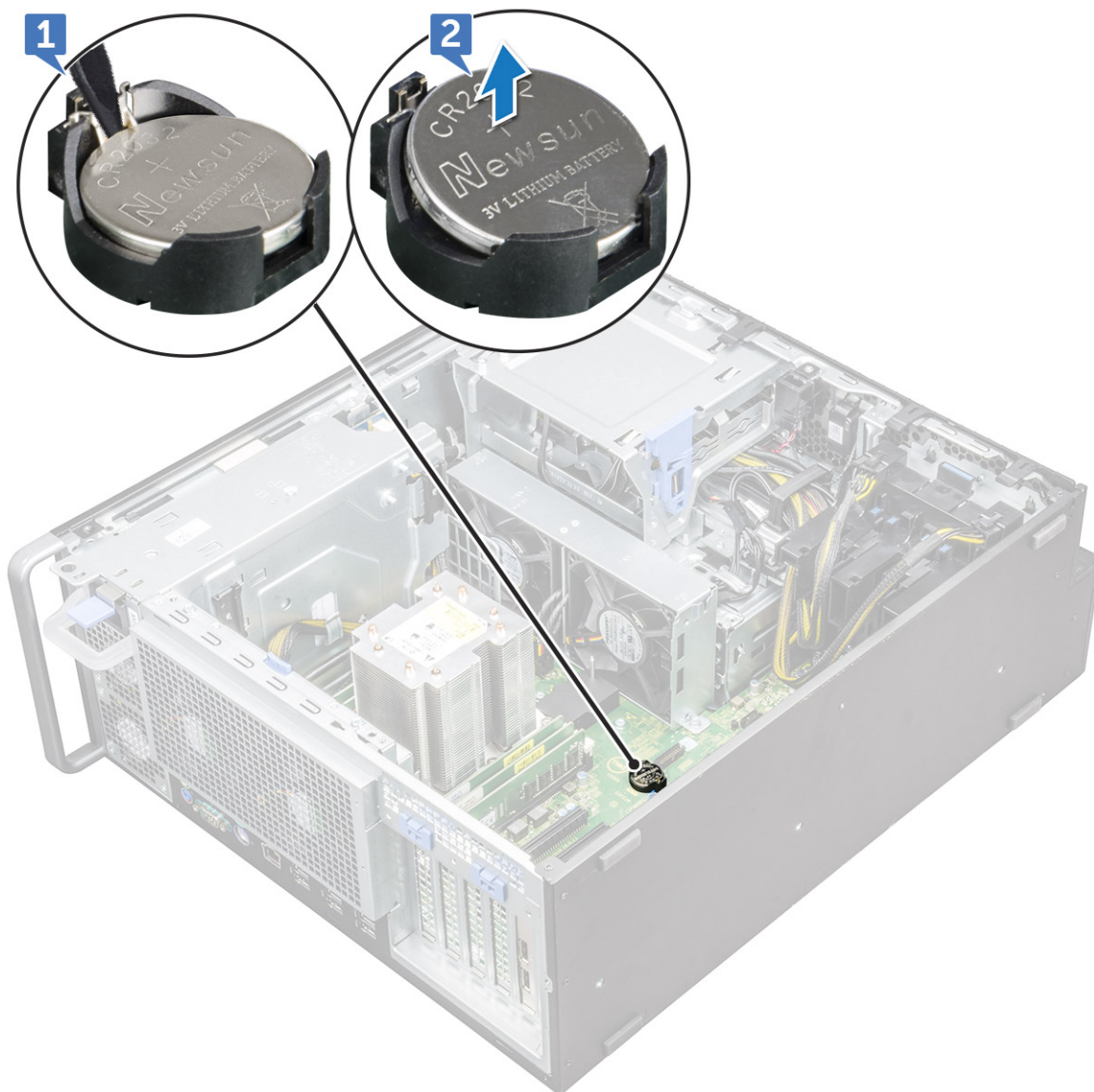

- b. Lift the coin-cell battery out of the system board.

Installing the coin cell battery

1. Place the coin-cell battery into its slot on the system board.
2. Press the coin-cell battery with positive (+) side facing up until the release latch springs back into place and secures it to the system board.
3. To install:
 - a. [graphical processing unit \(GPU\)](#)
 - b. [side cover](#)
4. Follow the procedure in [After working inside your computer](#).

Center System fan/HDD fan

Removing the Center System fan/HDD fan

1. Follow the procedure in [Before working inside your computer](#).
2. Remove the:

- a. side cover
 - b. air shroud
 - c. front bezel
 - d. 5.25 inch ODD bracket
 - e. graphical processing unit(GPU)
3. To remove the Center System fan/HDD fan:
- a. Press the connector tab and disconnect the two fan cables from the system board.
- NOTE:** Do not pull the connector by the cable wires. Instead, disconnect the cable by pulling on the connector end.
Pulling on the cable wires may loosen them from the connector.

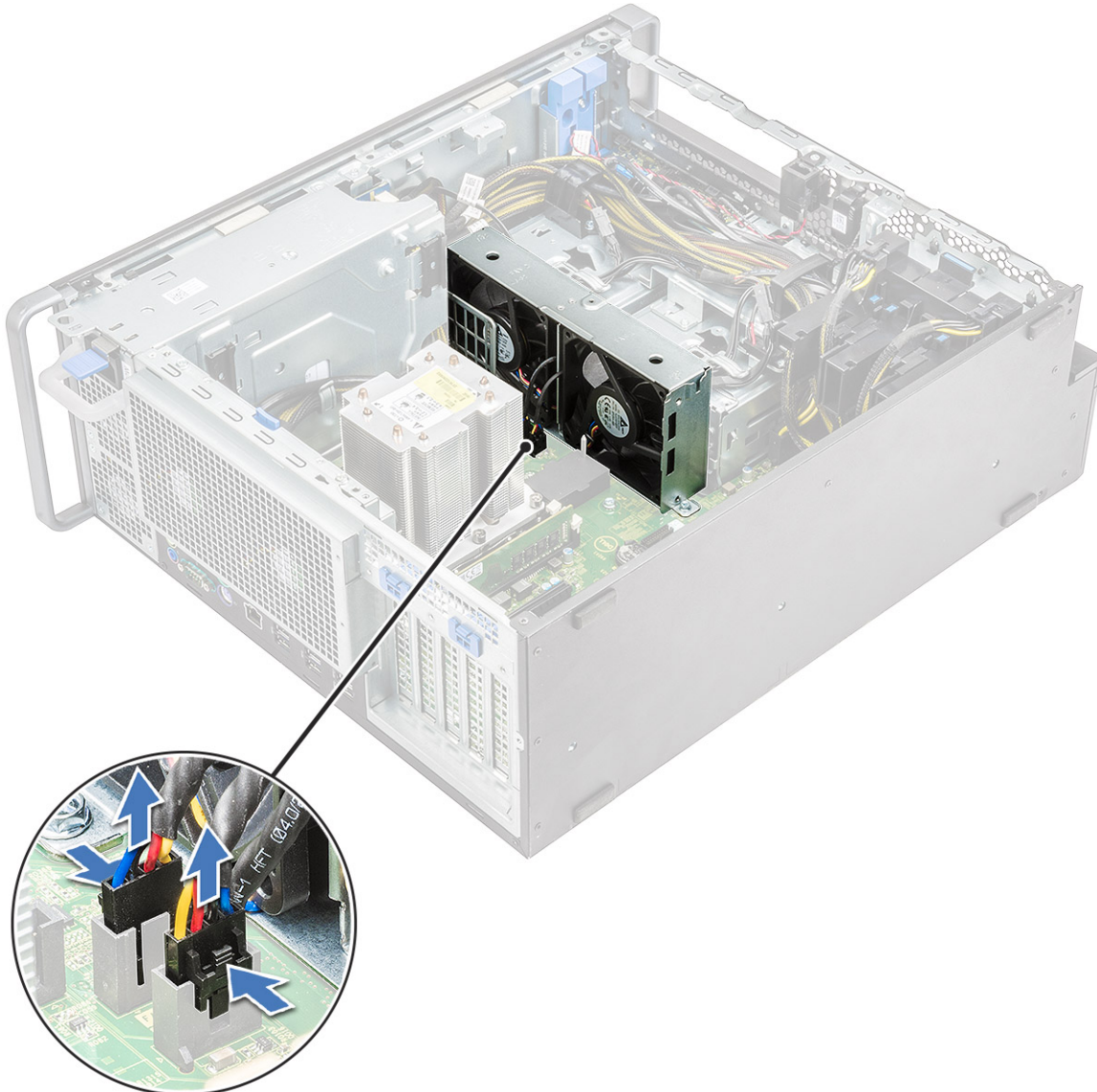

- b. Remove the screws [1] securing the Center System fan/HDD fan to the system board and lift the Center System fan/HDD fan up [2] .

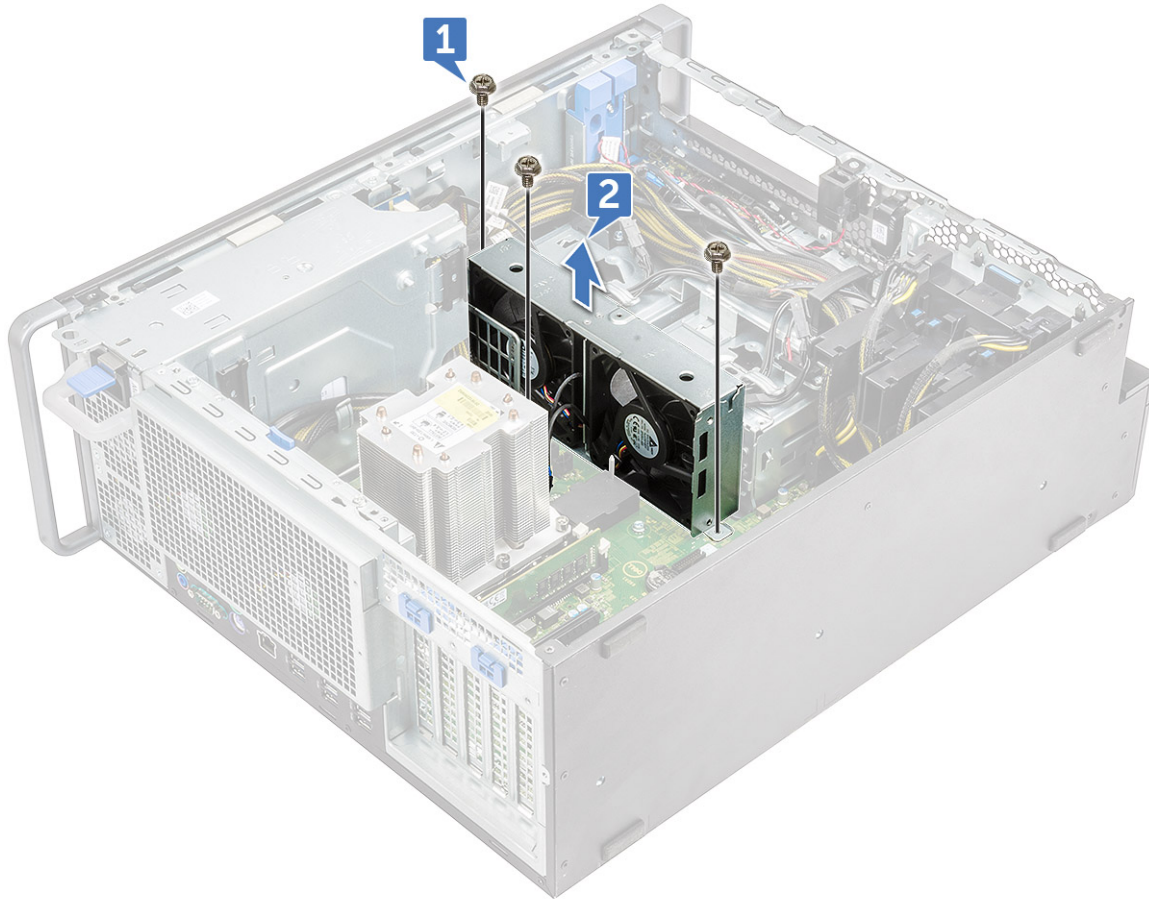

Installing the Center System fan/HDD fan

1. Align the Center System fan/HDD fan to its slot on the system board and secure it with the 3 screws.
2. Connect the fan cables to the slot on the system board.
3. Install the:
 - a. [graphical processing unit\(GPU\)](#)
 - b. [5.25 ODD bracket](#)
 - c. [front bezel](#)
 - d. [air shroud](#)
 - e. [side cover](#)
4. Follow the procedure in [After working inside your computer](#).

Fan bracket

Removing the fan from the fan bracket

1. Follow the procedure in [Before working inside your computer](#).
2. Remove the:
 - a. [side cover](#)
 - b. [Center System fan/HDD fan](#)
3. To remove the fan from the fan bracket:
 - a. Slide out the four rubber grommets for each fan from the fan chassis [1].

- b. Lift the fan and remove it from the fan assembly [2].



Installing the fan into the fan bracket

1. Place the fan into the fan bracket.
2. Tighten the grommets that secure the fan to the fan bracket.
3. Install the:
 - a. [Center System fan/HDD fan](#)
 - b. [side cover](#)
4. Follow the procedure in [After working inside your computer](#)

PCIe holder

Removing PCIe holder

1. Follow the procedure in [Before working inside your computer](#).
2. Remove the:
 - a. [side cover](#)
 - b. [graphical processing unit\(GPU\)](#)
3. To remove the PCIe holder:
 - a. Disconnect the two power cables from the cable slot in the PCIe holder [1].
 - b. Press the PCIe holder securing clip and slide the holder [2] out of the chassis.

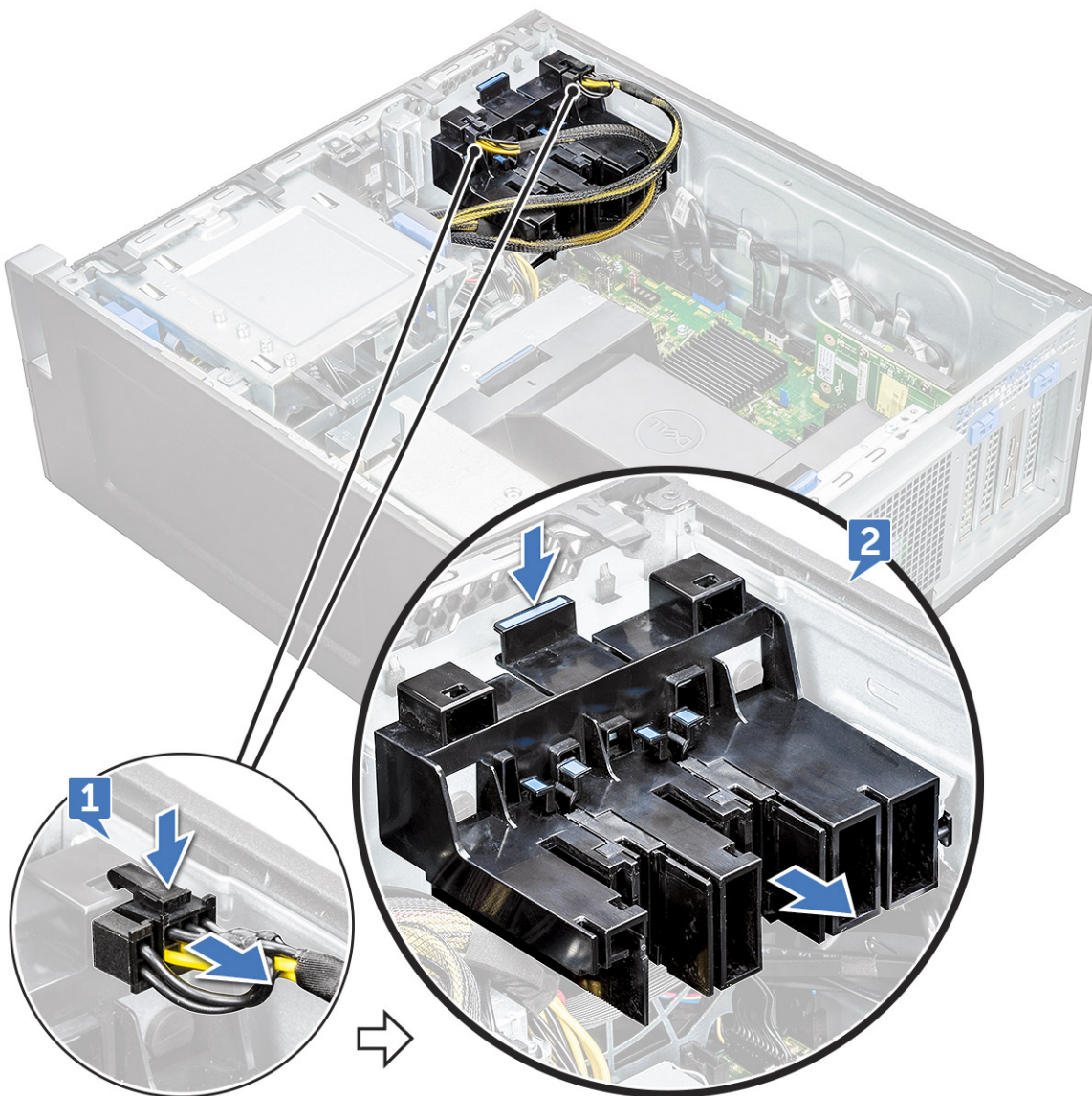

Installing the PCIe holder

1. Align and place the PCIe holder to the system chassis.
2. Press the holder back until it clicks to the system.
3. Connect the two power cables to the cable slots in the holder.
4. Install the:

- a. graphical processing unit(GPU)
 - b. side cover
5. Follow the procedure in [After working inside your computer](#).

Rear system fan

Removing the rear system fan

1. Follow the procedure in [Before working inside your computer](#).
2. Remove the:
 - a. side cover
 - b. processor heat sink module(PHM)
3. To remove the rear system fan:
 - a. Disconnect the two fan cables [1] from the system board.
i NOTE: Do not pull the connector by the cable wires. Instead, disconnect the cable by pulling on the connector end.
Pulling on the cable wires may loosen them from the connector.
 - b. Unroute the cable from the cable holder [2] on the PSU bracket.

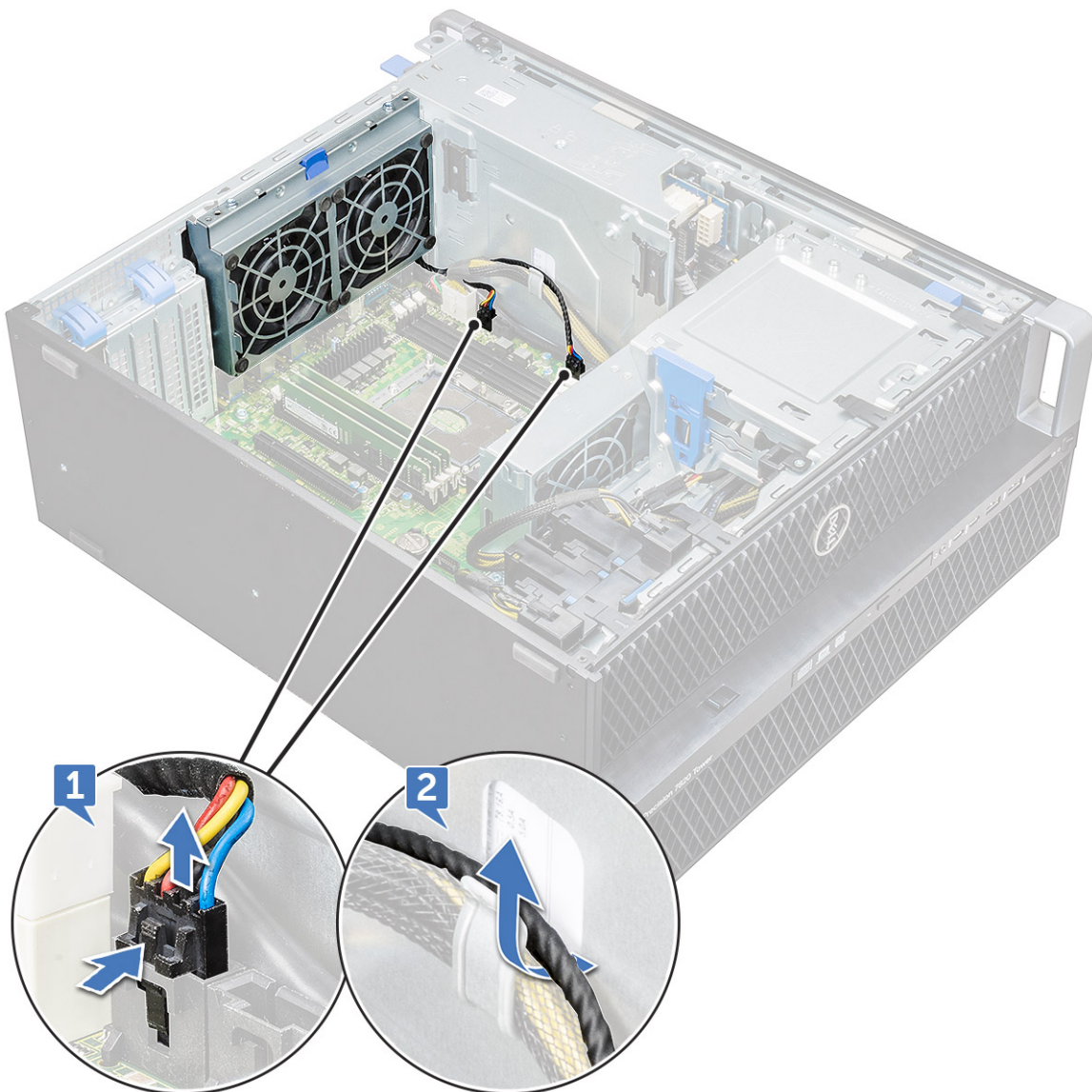

- c. Remove the screws [1].
- d. Press the tab[2] to detach the fan from the system.

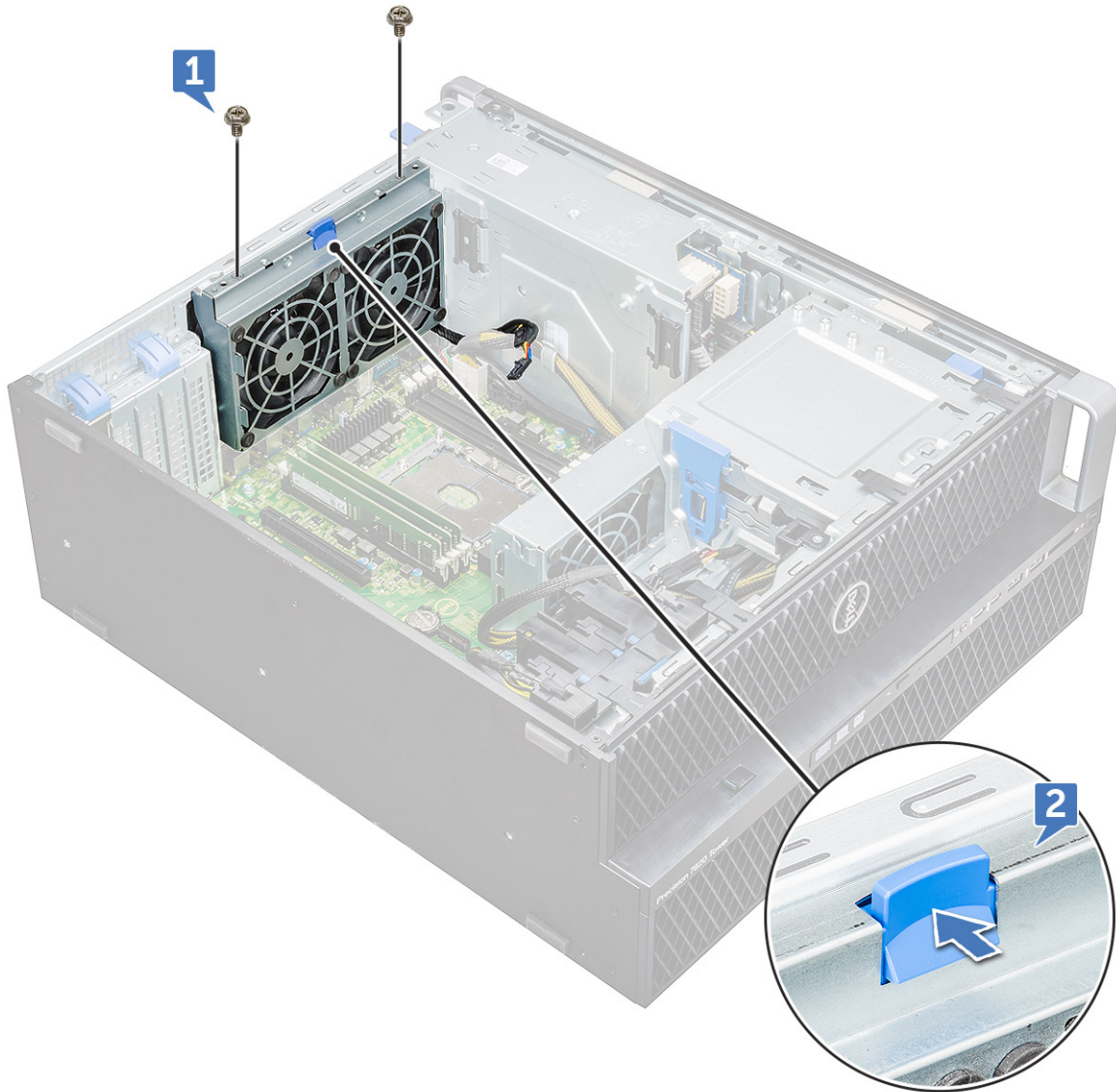

- e. Rotate the fan forward and lift it away from the system.



Installing the rear system fan

1. Insert the fan assembly on one side to align it with the screw tab on the PSU bracket.
2. Press the assembly on the other side to align it with the screw tab on the PCI bracket.
3. Tighten the two screws to secure it with the system.
4. Connect the two fan cables to the system board.
5. Install the:
 - a. [processor heat sink module\(PHM\)](#)
 - b. [side cover](#)
6. Follow the procedure in [After working inside your computer](#).

Front system fan

Removing the front system fan

1. Follow the procedure in [Before working inside your computer](#).
2. Remove the:
 - a. [side cover](#)
 - b. [front bezel](#)
 - c. [PCIe holder](#)
 - d. [graphical processing unit \(GPU\)](#)

3. To remove the front system fan:

a. Unroute the following cables from the card holder [5]:

- SATA 0,1 cable [1]
- SATA 2, 3, 4, 5 cable [2]
- ODD 0, 1 cable [3]
- USB 3.1 cable [4]

i **NOTE:** Do not pull the connector by the cable wires. Instead, disconnect the cable by pulling the connector end. Pulling the cable wires may loosen them from the connector.

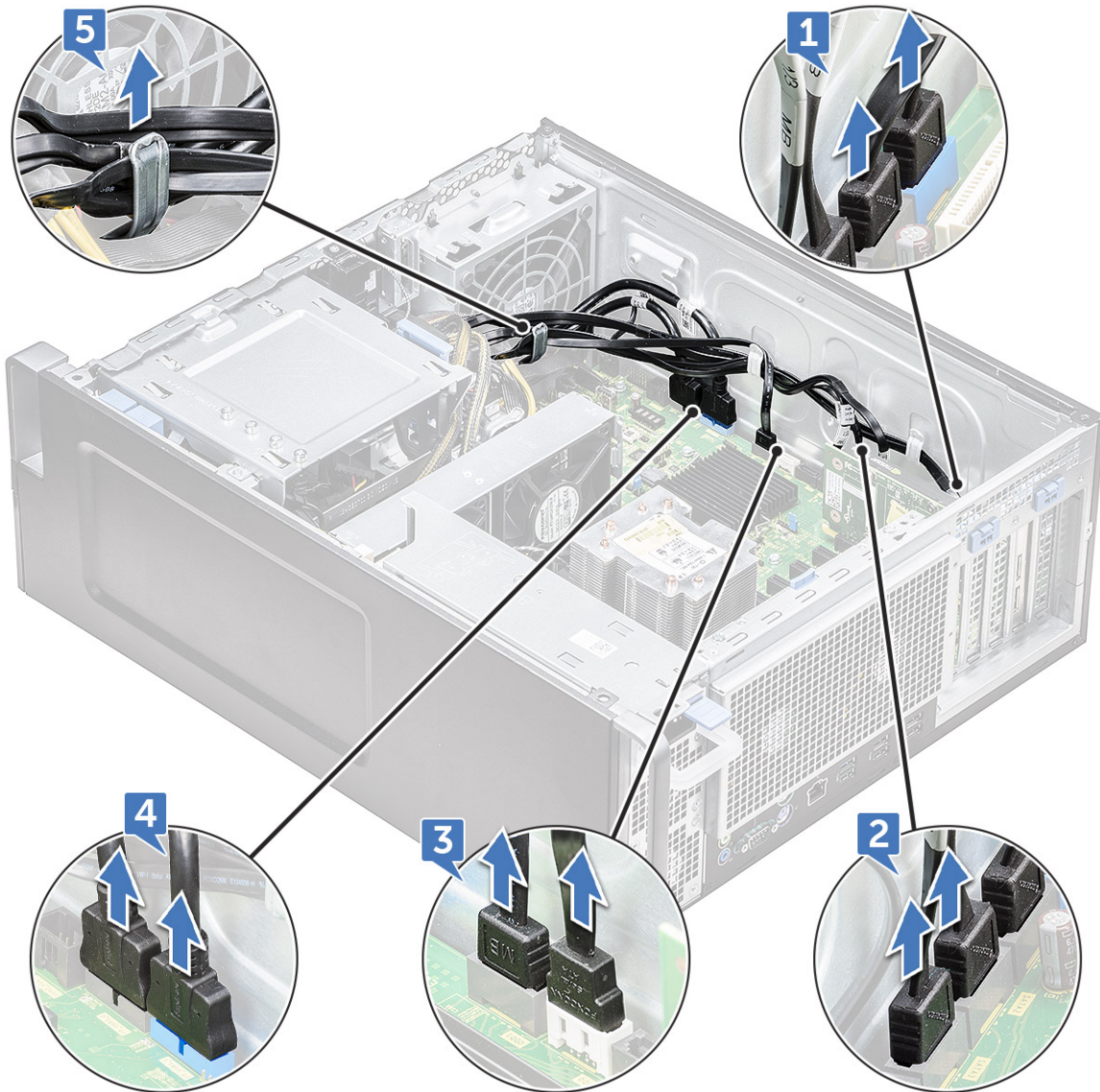

b. Unroute the fan cable [1] from the system board.

c. Remove the screw [2] that secure the front system fan to the chassis.

d. Lift the fan to release it from the retention slot in the system chassis [3].

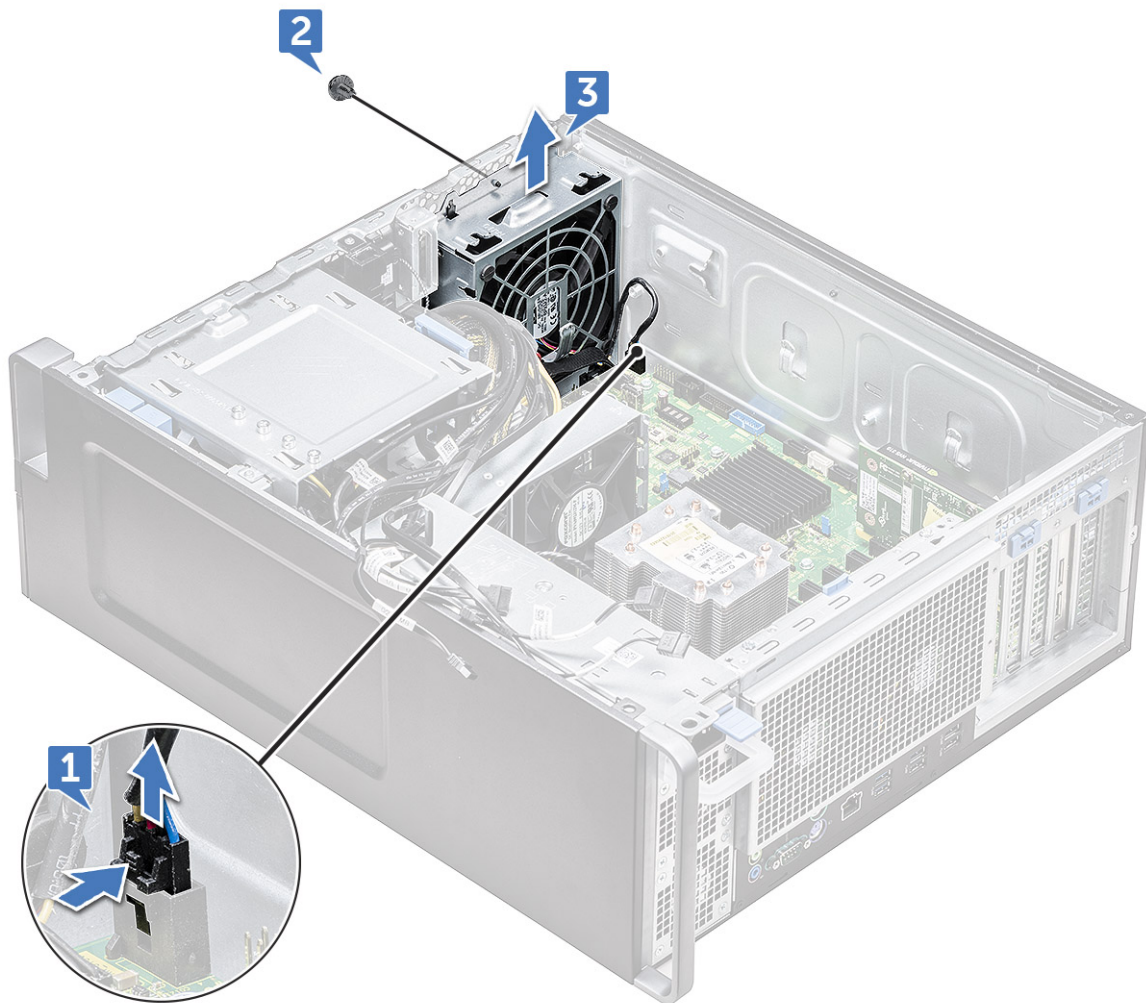

Installing the front system fan

1. Align the front system fan to its retention slot in the system chassis.
2. Replace the screw that secures the front system fan to the chassis.
3. Connect the fan cable to the system board.
4. Route the following cables through the cable holder and connect to the system board:
 - SATA 2, 3, 4, 5 cable
 - SATA 0, 1 cable
 - ODD 0, 1 cable
 - USB 3.1 cable
5. Install the:
 - a. [PCIe holder](#)
 - b. [graphical processing unit \(GPU\)](#)
 - c. [front bezel](#)
 - d. [side cover](#)
6. Follow the procedure in [After working inside your computer](#).

Processor heat sink module

Removing the processor heat sink module

1. Follow the procedure in [Before working inside your computer](#).

NOTE: Ensure that you have Torx 30 screwdriver to remove the processor heat sink module (PHM).

2. Remove the:

- a. [side cover](#)
- b. [air shroud](#)

3. To remove the heat sink:

- a. Remove the four heat sink screws [1], in the diagonal order (4, 3, 2, 1).
- b. Lift the heat sink away from the CPU slot on the system board.

CAUTION: CPU will be removed with the heat sink.

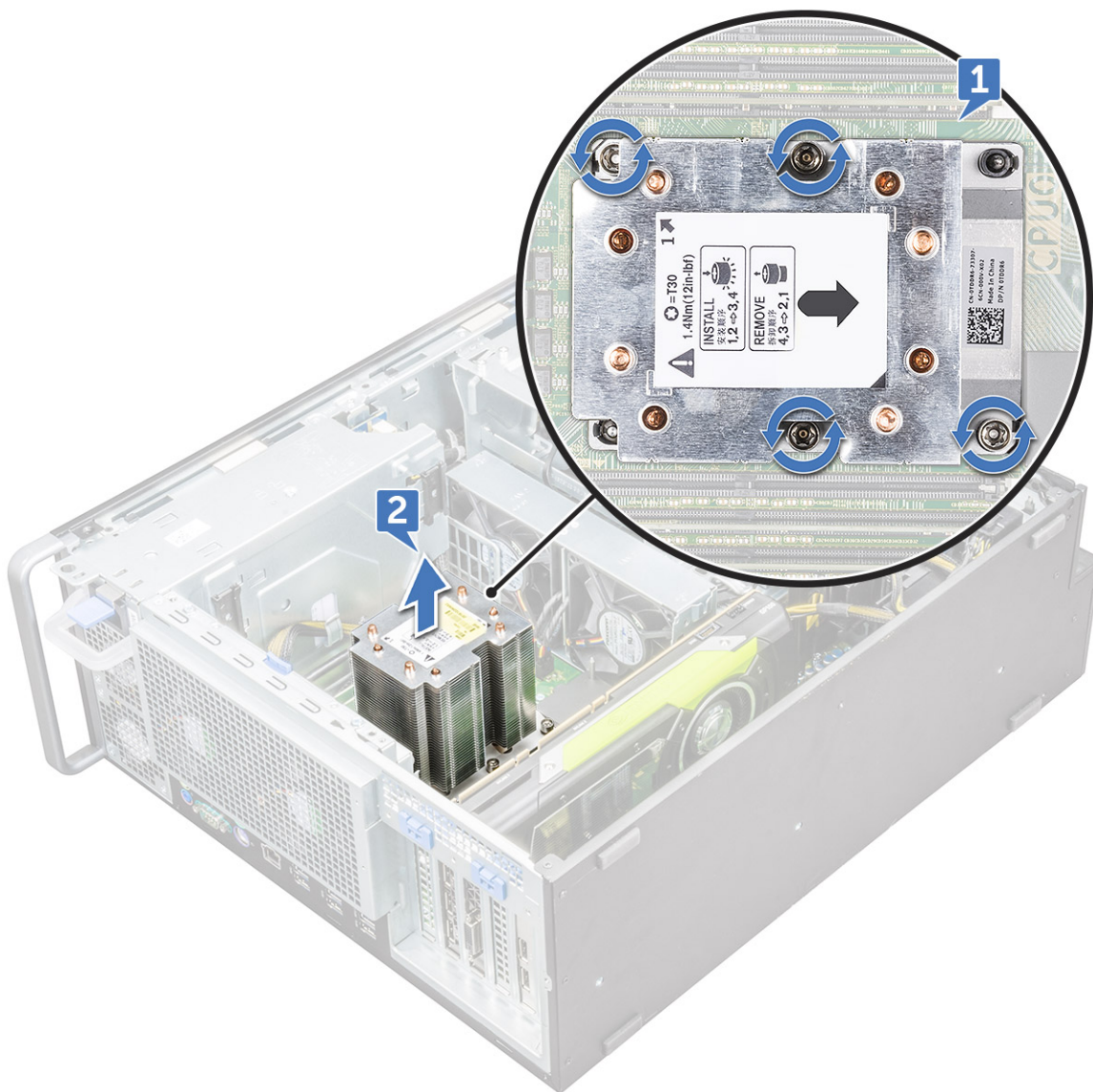

Installing the processor heat sink module

1. Place the heat sink on the CPU slot.
2. Replace the four screws in the diagonal order (1,2,3,4), to secure the heat sink to the system board.
3. Install the:
 - a. [air shroud](#)
 - b. [side cover](#)
4. Follow the procedure in [After working inside your computer](#).

Removing the CPU

1. Follow the procedure in [Before working inside your computer](#).
2. Remove the:
 - a. [side cover](#)
 - b. [air shroud](#)
 - c. [processor heat sink module](#)
3. To remove the central processing unit (CPU):
 - a. Hold the processor heat sink module upside down.
 - b. Pry the two processor carrier latches [1] from the processor heat sink module.
 - c. Press the other two carrier latches [2] of the processor carrier and remove it from the slot in the heat sink.

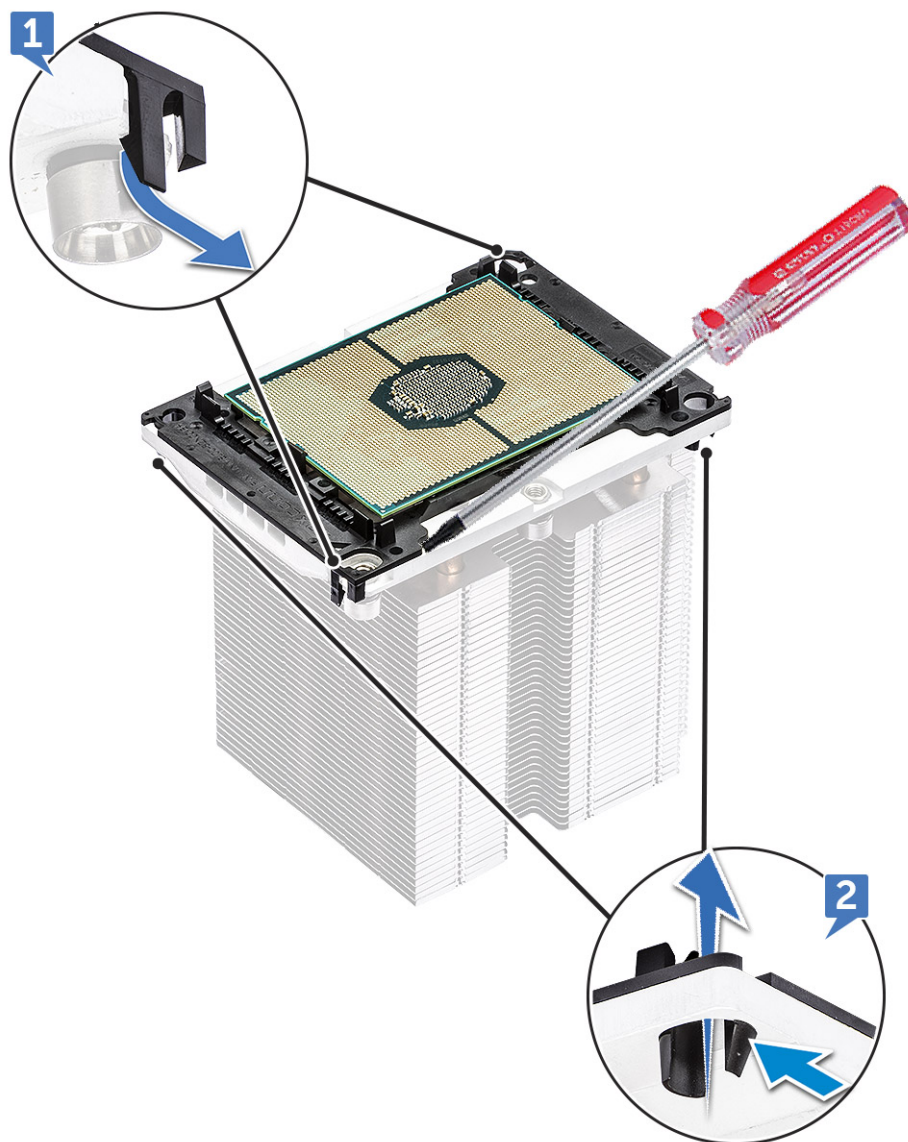

d. Use a torx screwdriver to pry the CPU off the processor heat sink module. Place the blade between the clip and the CPU.

i **NOTE:** A flatbed screwdriver or plastic scribe can also be used as well.

e. Unlatch the CPU from the two keying latches on the processor carrier and gently lift the CPU.

i **NOTE:** Avoid touching the CPU contacts with your fingers.

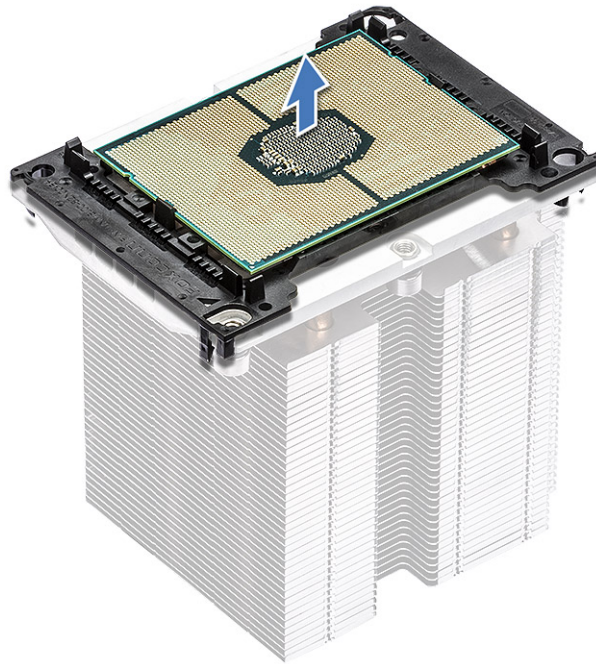

Installing the CPU

1. Orient the processor carrier so that the smooth (logo-less) side of the carrier is facing up and the triangle mark on the carrier is on the bottom left hand corner.

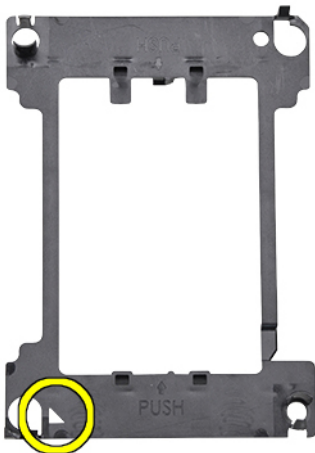

2. Align the processor with the carrier so that the triangle mark on the top side of the processor is aligned with the triangle mark on the carrier.

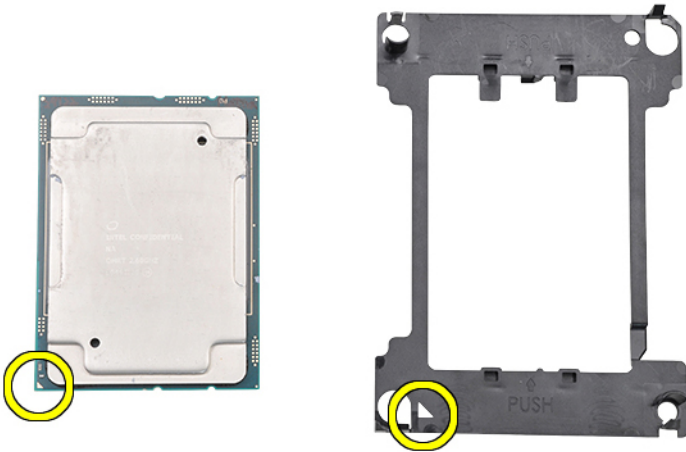

3. Flip both the processor and the carrier over so that the pins on the processor and the logo side of the carrier are facing up.

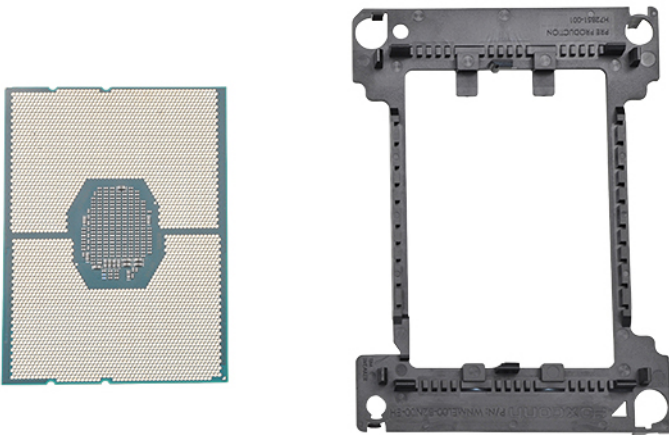

4. Carefully insert the processor into the carrier so that it is secured by the hooks on the upper and lower side of the carrier.

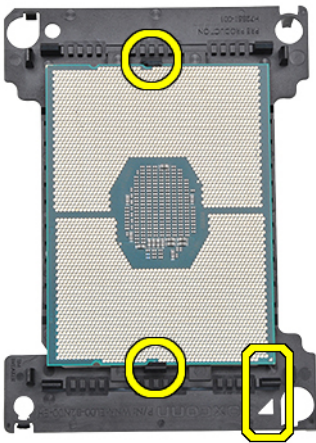

NOTE: After inserting the processor into the carrier, check to see whether the small triangle on the processor aligns with the triangle on the carrier. If they are not aligned repeat the preceding steps.

5. Align the processor and carrier assembly with the heat sink so that the triangle marks on the processor and carrier are aligned with the triangle mark on the top side of the heat sink (captive screw #2).

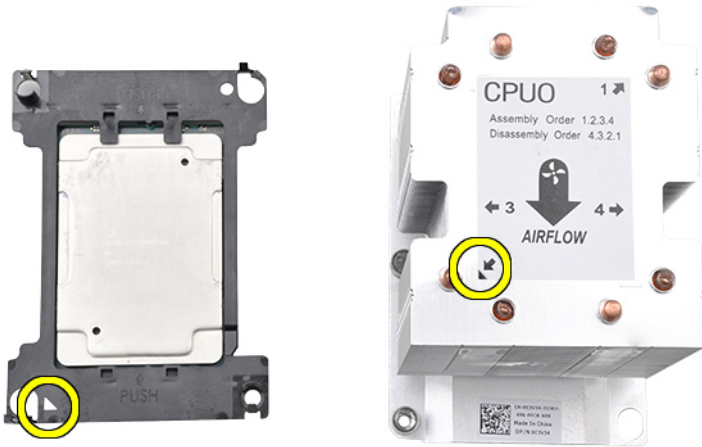

6. Insert the processor and carrier assembly into the heat sink so that the hooks on the four corners of the carrier are locked into the openings of heat sink.

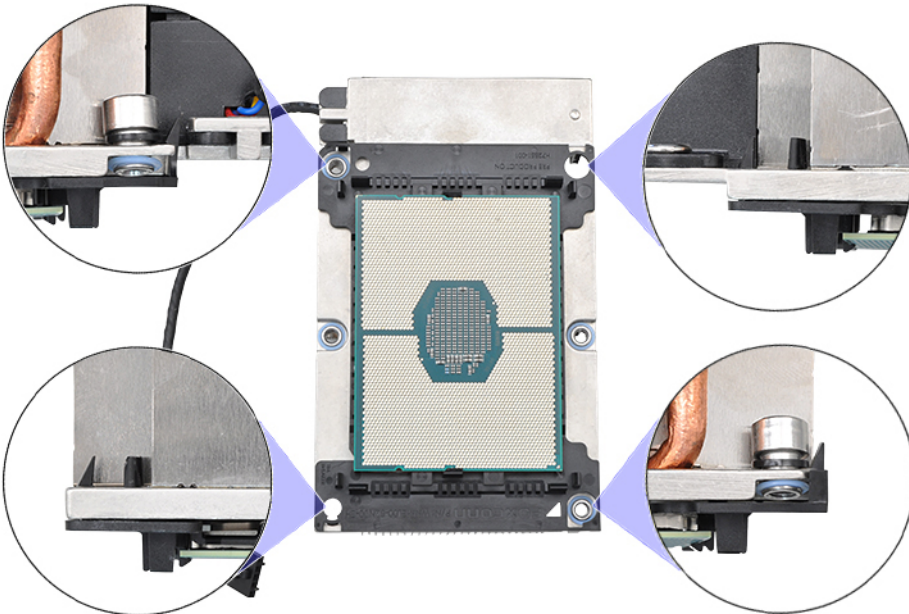

NOTE: After inserting the processor and carrier assembly into the heat sink, double check to see whether the triangle on the carrier is located on the bottom right corner of the heat sink (when the bottom side of the heat sink is facing up).

7. Install the processor and heat sink onto the central processing unit (CPU) socket and then secure the four captive screws on the heat sink to the system board in sequential order (1 > 2 > 3 > 4).

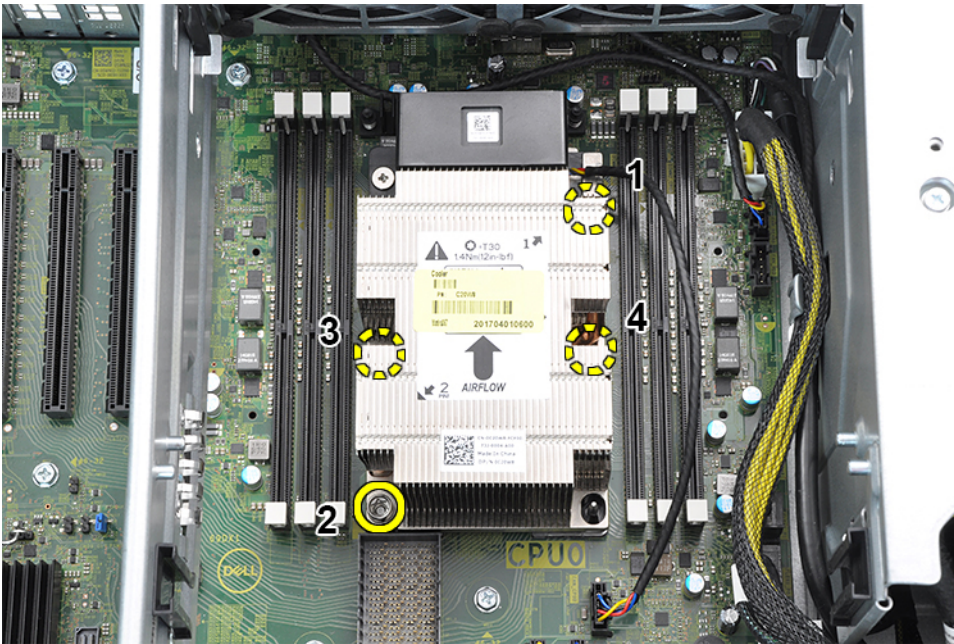

8. Install the:
 - a. [heat sink](#)
 - b. [air shroud](#)
 - c. [side cover](#)
9. Follow the procedure in [After working inside your computer](#)

Removing the Riser Card and Dual Processor configuration

1. Follow the procedure in [Before working inside your computer.](#)
2. Remove the [side cover](#).
3. To remove the central processing unit (CPU):
 - a. Remove the air shroud.

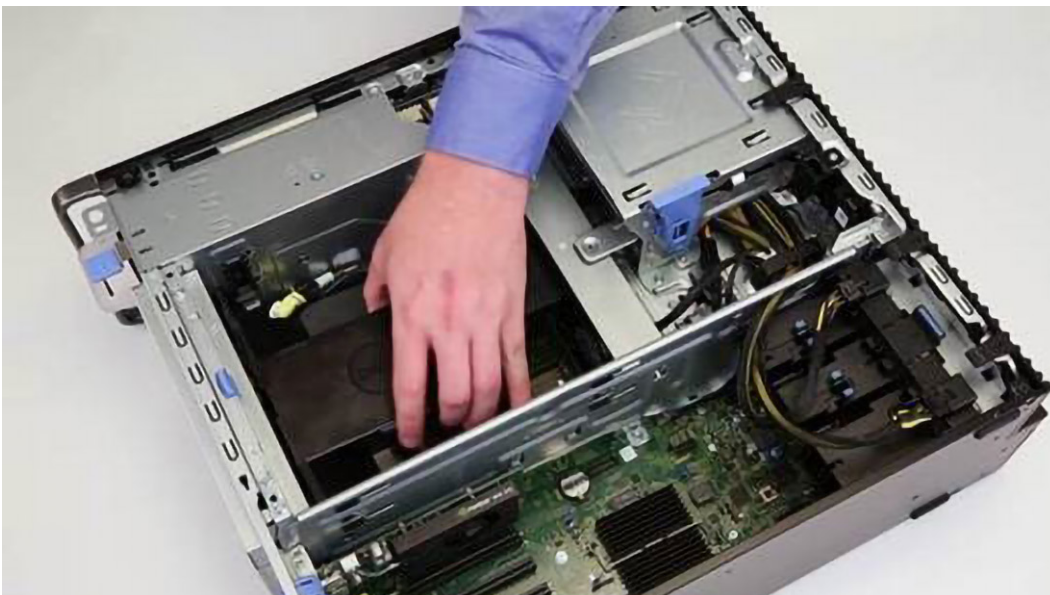

- b. Loosen the screws [1] and remove the heatsink assembly along with the processor.

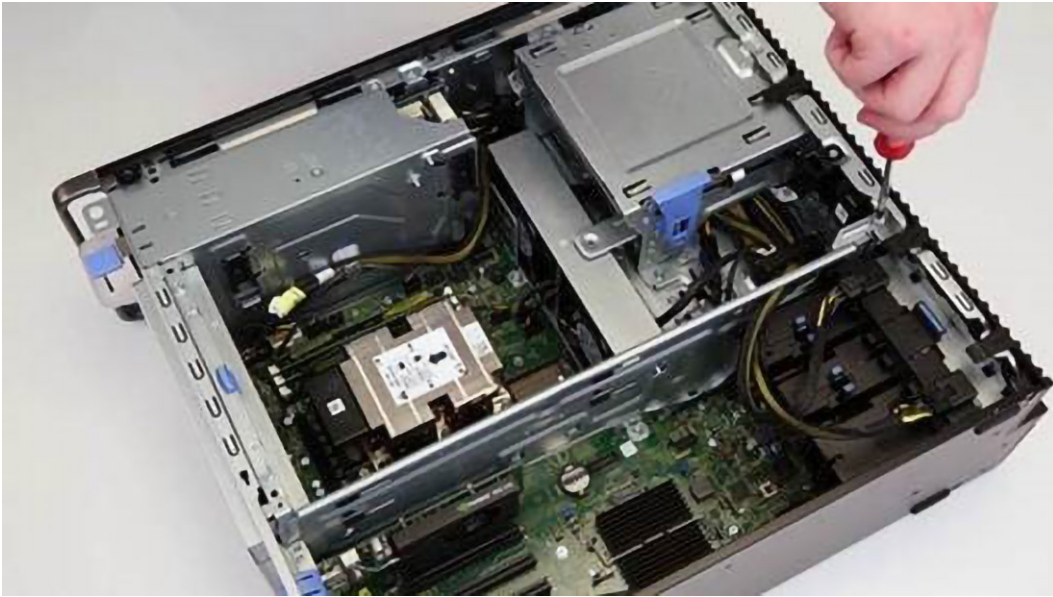

c. Disconnect the power cable from the riser card.

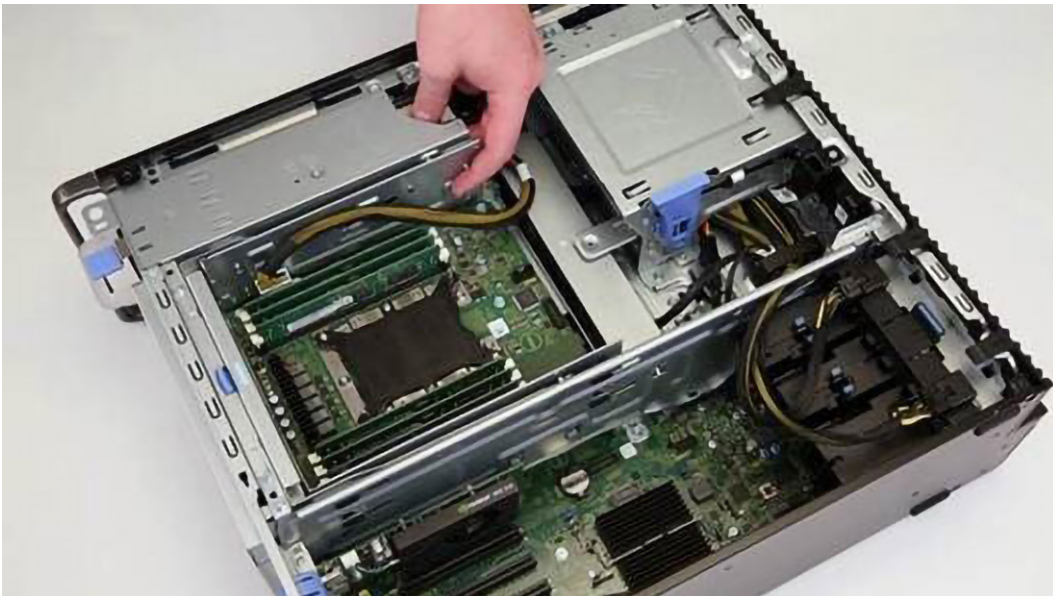

d. Press and release the riser card latch.

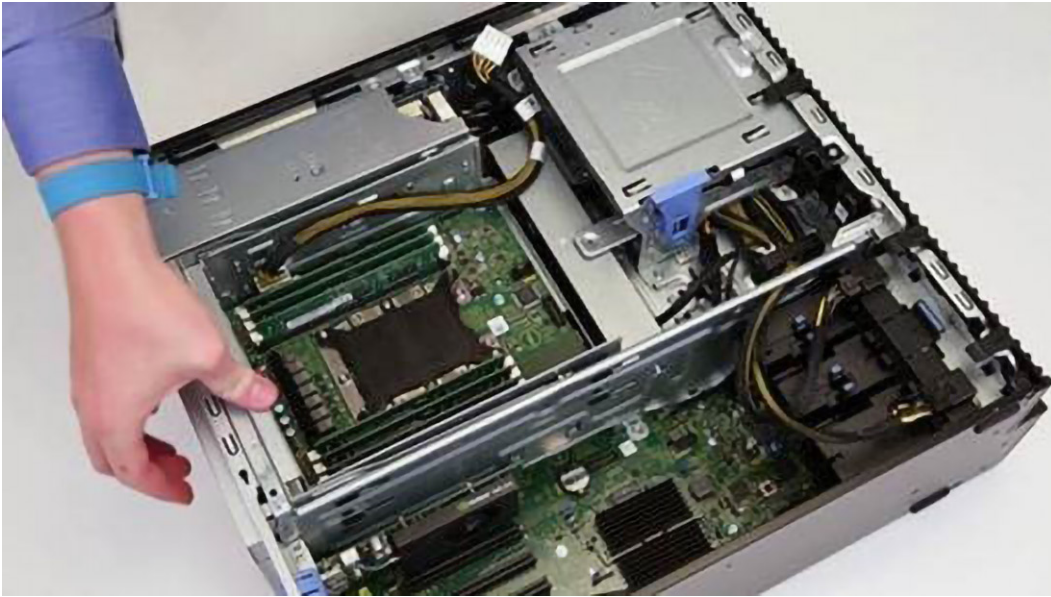

- e. Lift and remove the riser card from the computer.

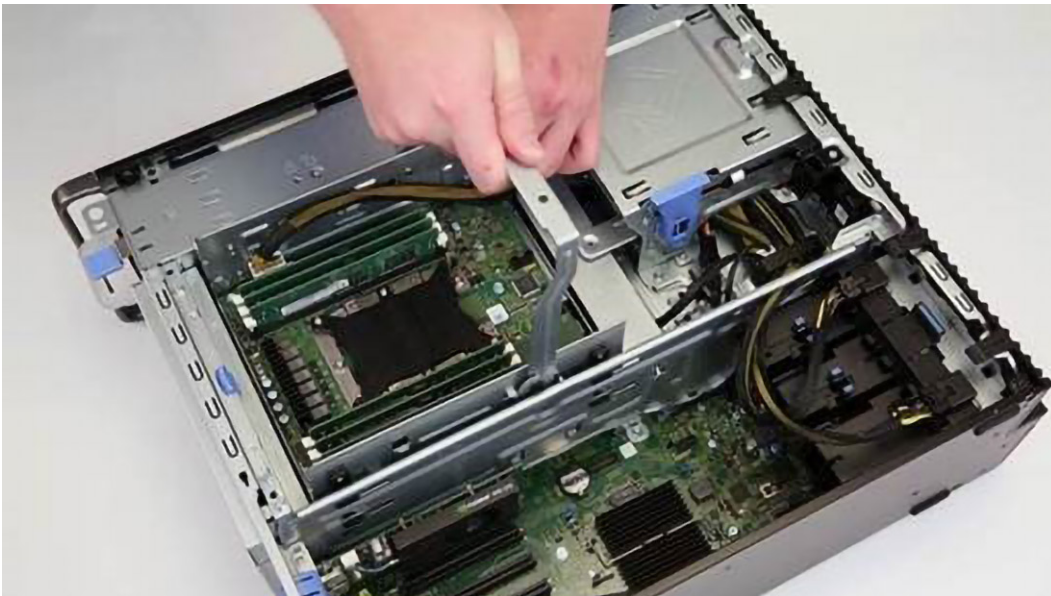

- 4. To remove the CPU0 and the heatsink assembly:
 - a. Remove the air shroud on the CPU0.

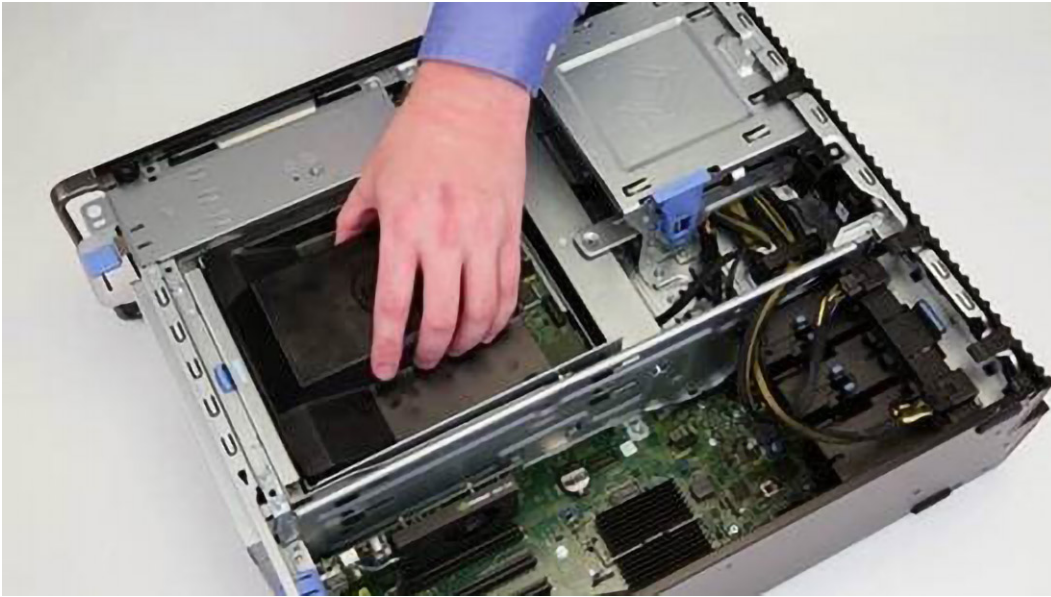

b. Remove the screw securing the metal bracket to the chassis.

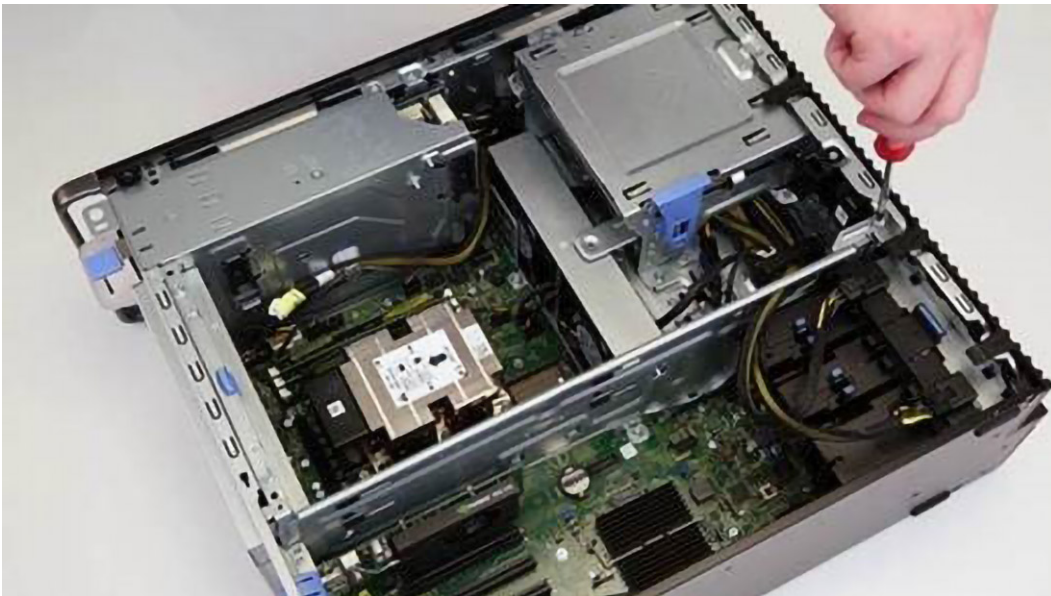

c. Disconnect the HDD and ODD cable and remove the metal separator from the system.

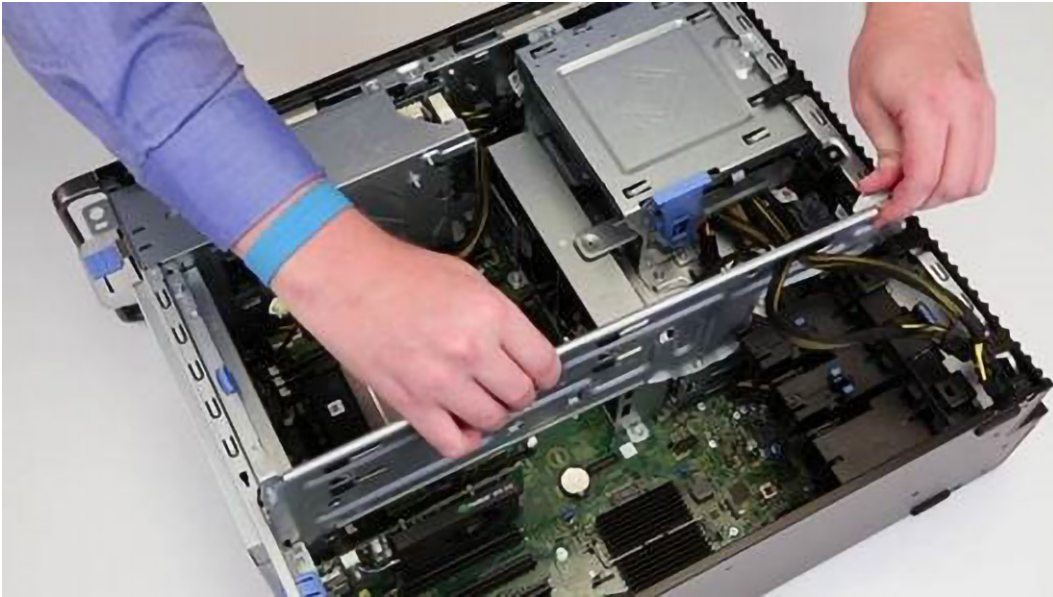

d. Loosen the heatsink screws from the system board.

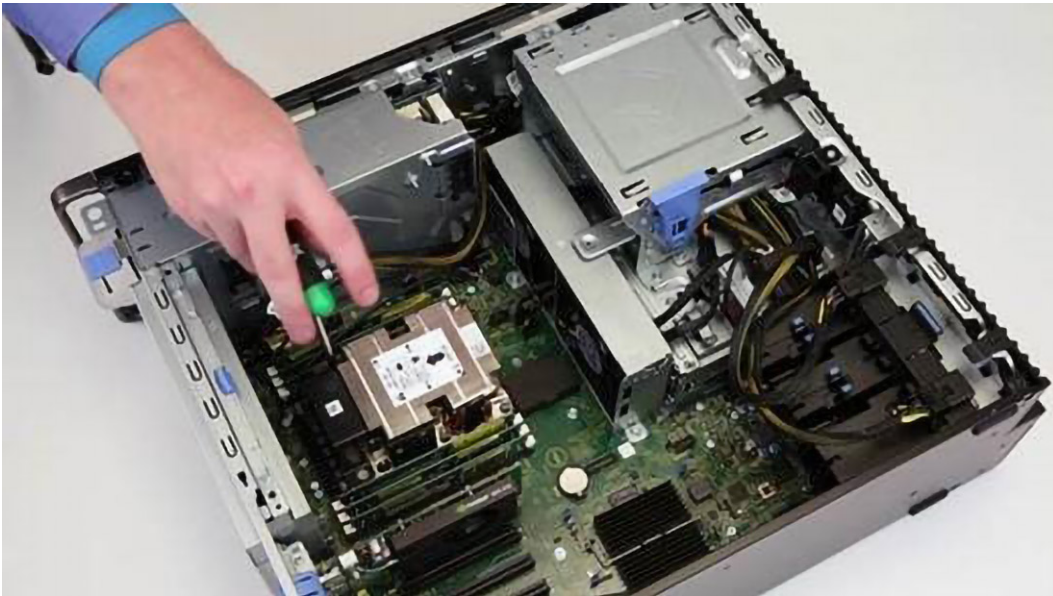

e. Disconnect the fan cable from the system board.

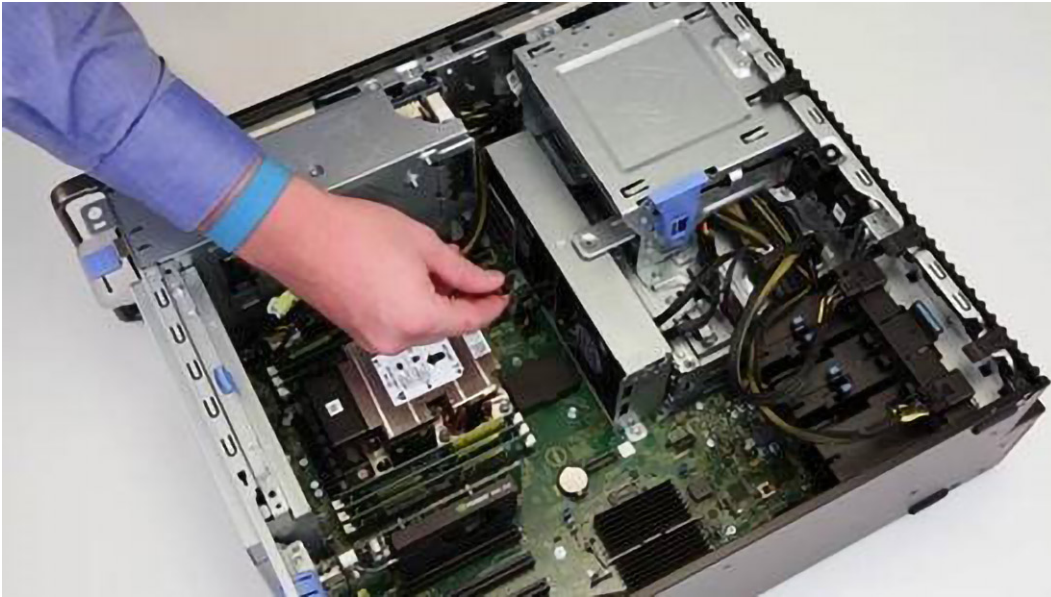

- f. Lift and remove the CPU0 along with heatsink from the computer.

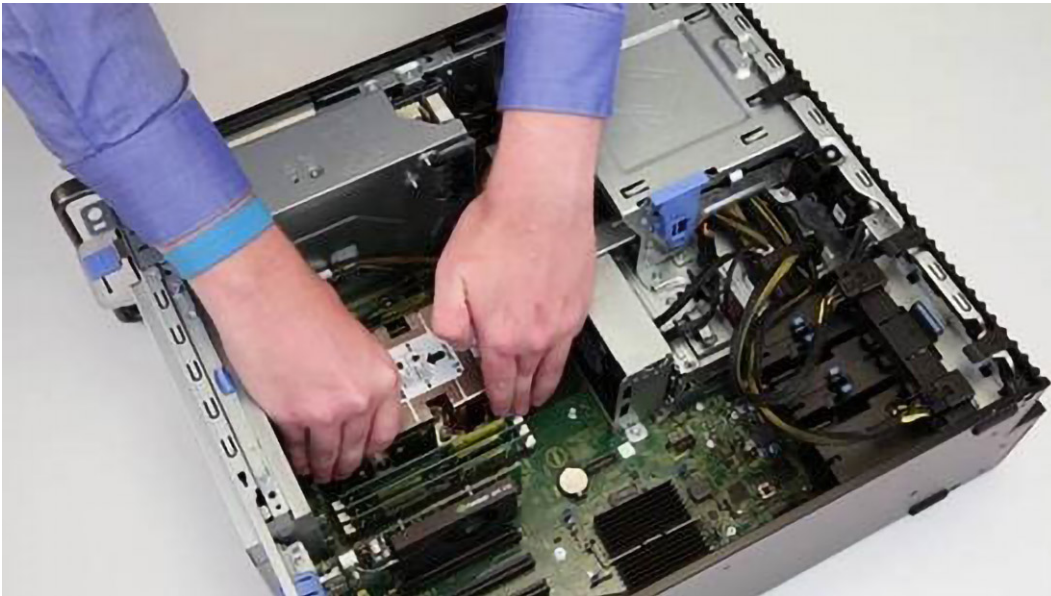

- 5. To remove the processor from the heatsink assembly:
 - a. Press and release the latch that secures the CPU to the heatsink assembly.

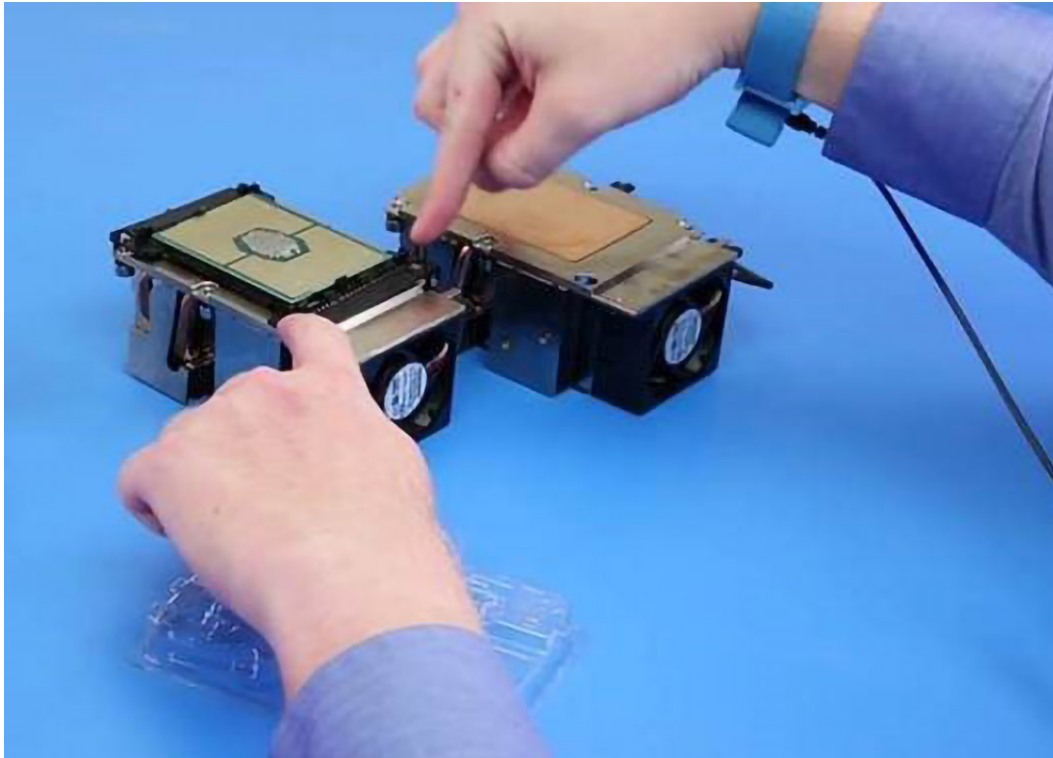

b. Pry the securing tabs to release the processor from the heatsink assembly.

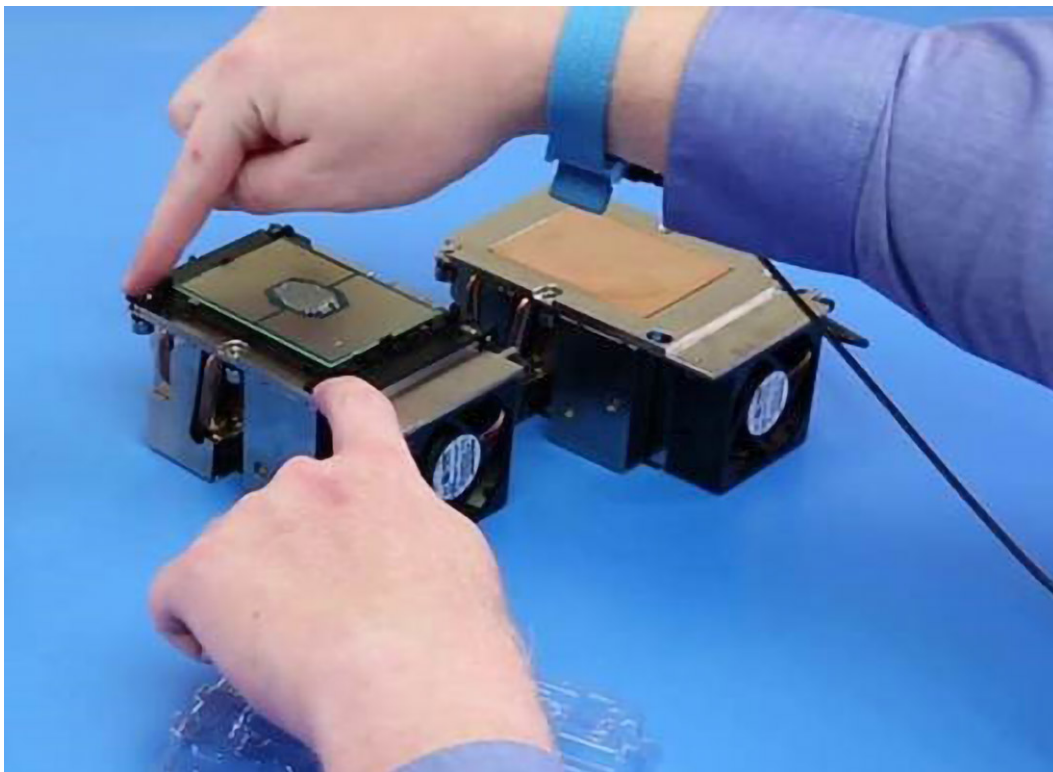

Installing the Riser Card and Dual Processor configuration

1. To install the processor on the heatsink assembly:
 - a. Apply thermal gel on the processor.

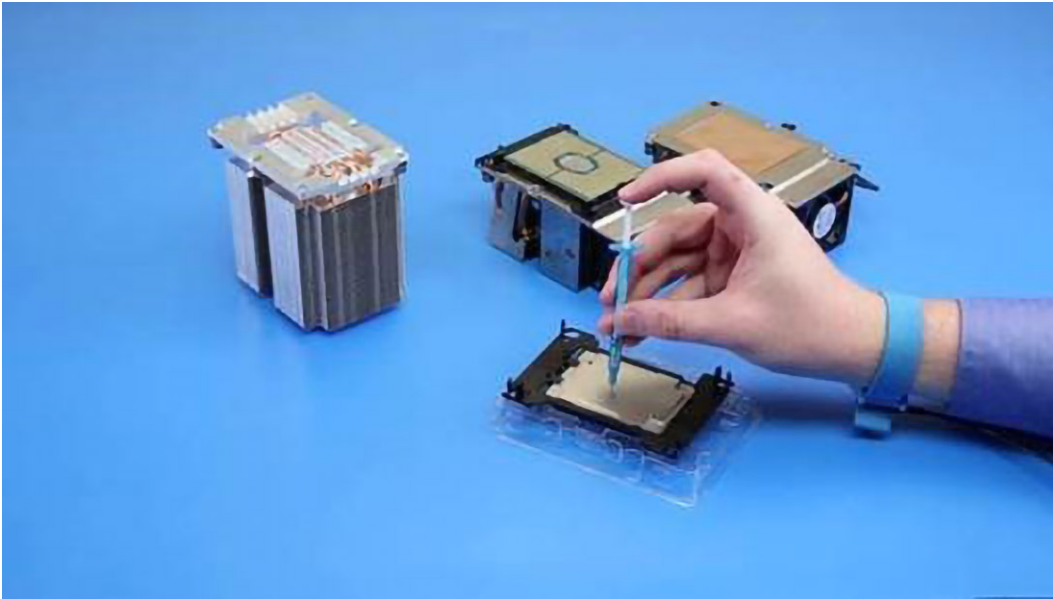

b. Replace the processor on the heatsink assembly.

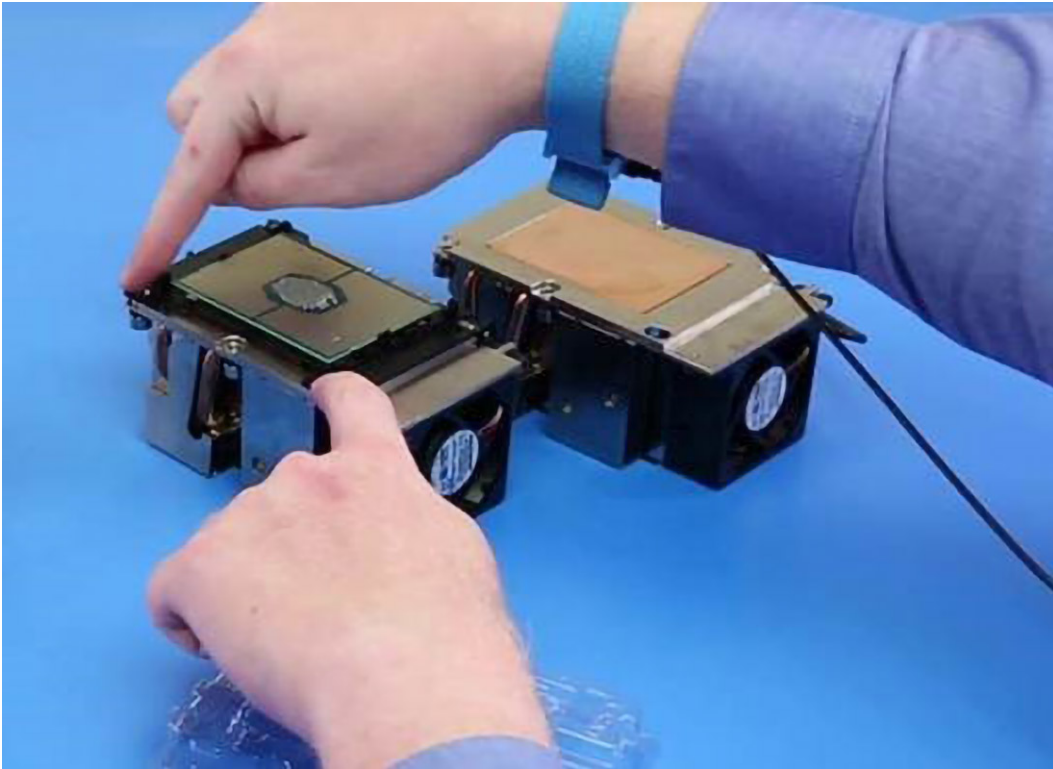

c. Press the latch to secure the processor on the heatsink assembly.

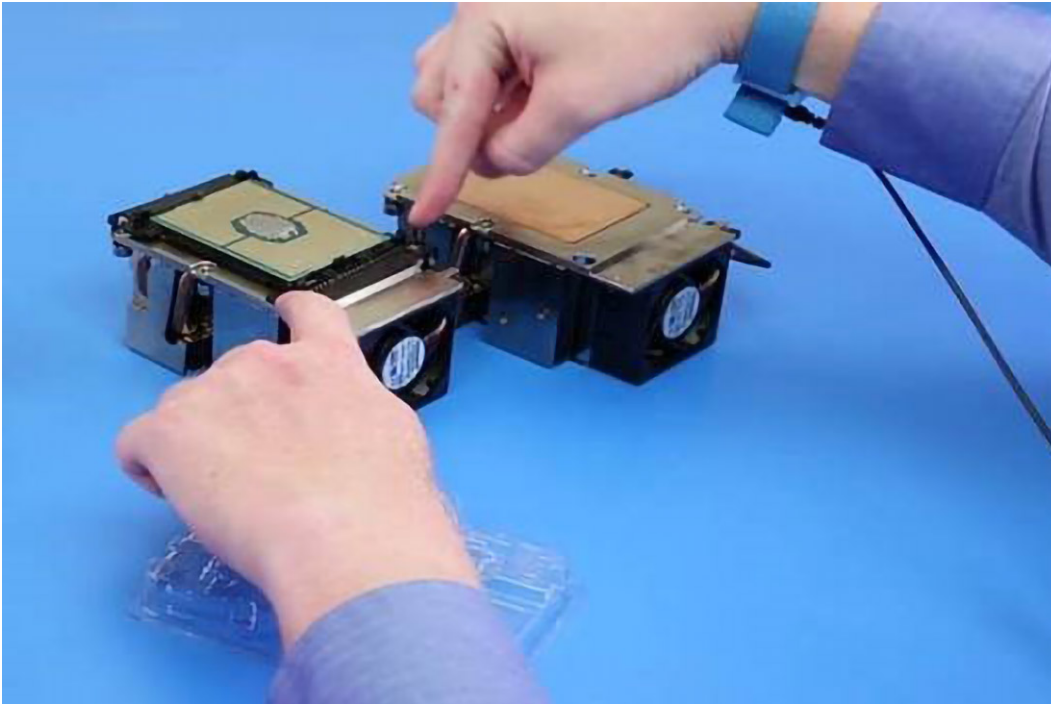

2. Install the CPU 0 and the heatsink assembly

- a.  **NOTE:** 6 Memory slots for the CPU1 are built on to the riser card.

Install the CPU 0 preassembled with the heatsink assembly on the system board.

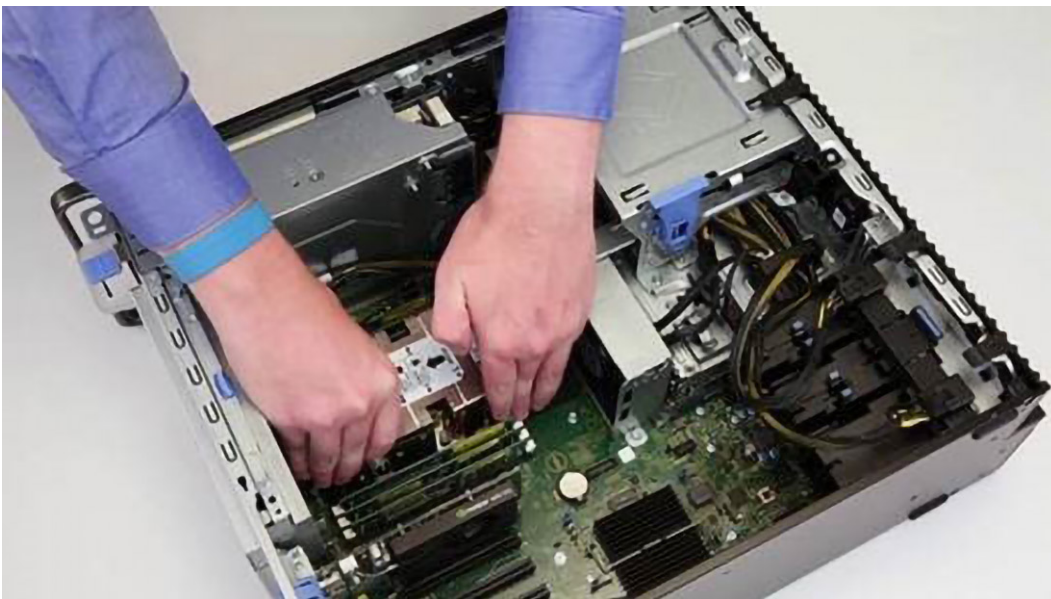

- b. Connect the fan cable for CPU 0 to the system board.

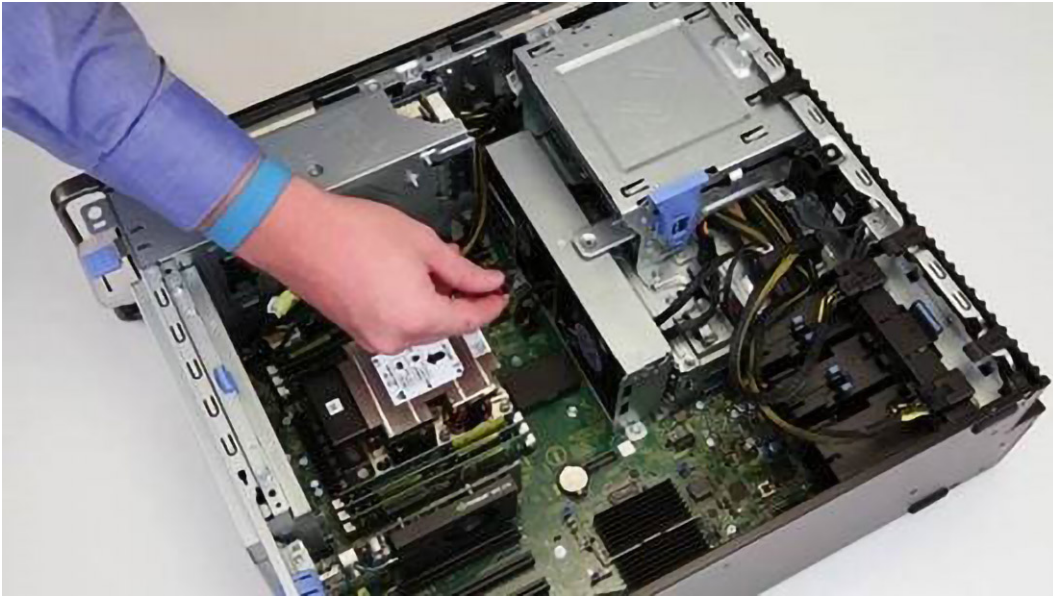

c. Tighten the heatsink screws to the system board

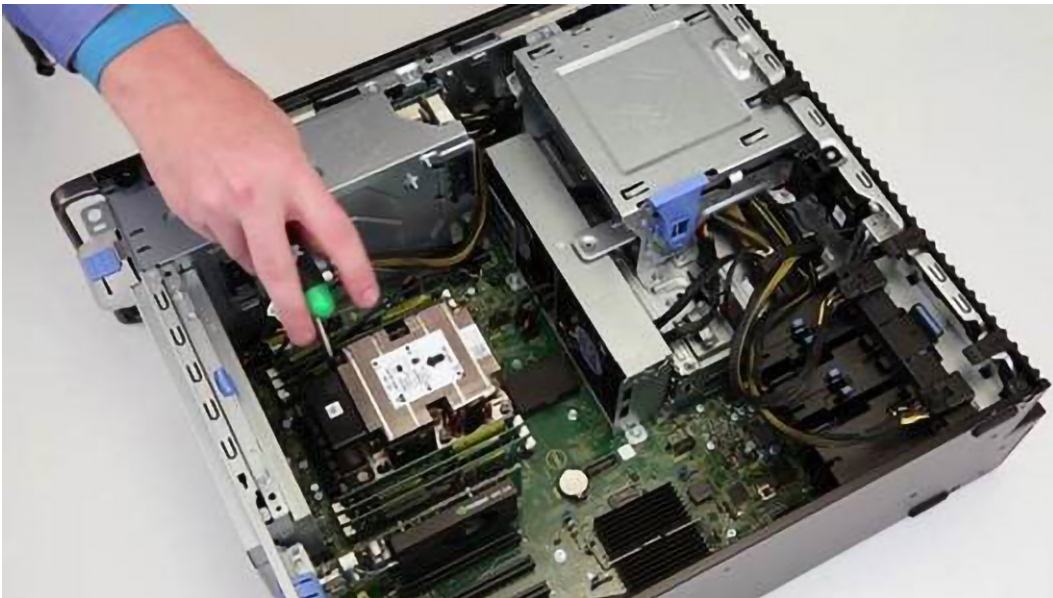

d. Remove the cap from the CPU 1 connector(in upgrading scenarios)

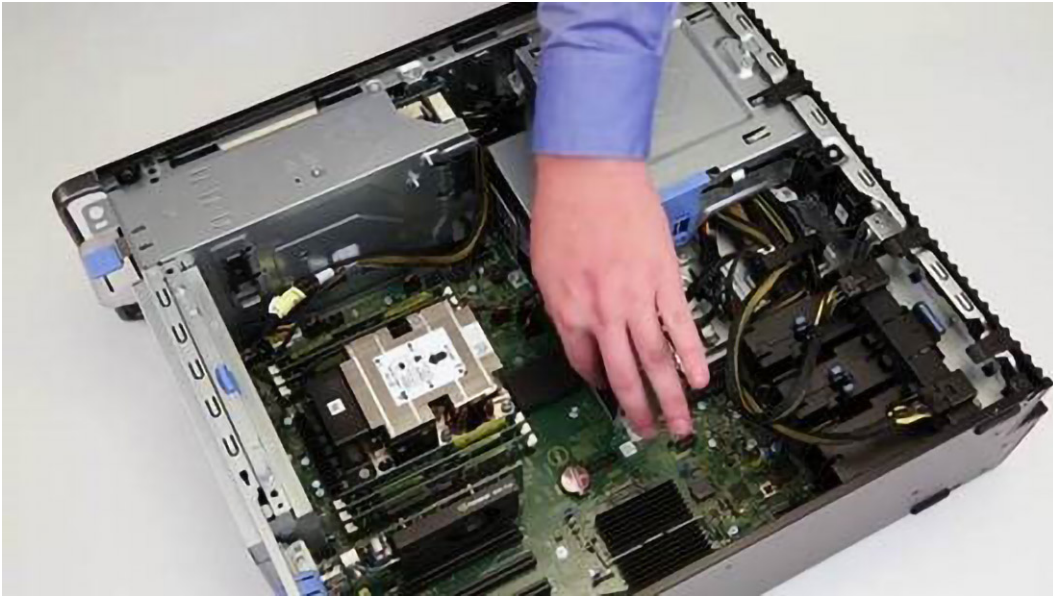

- e. Pass the hard drive and optical drive cable through the metal separator.

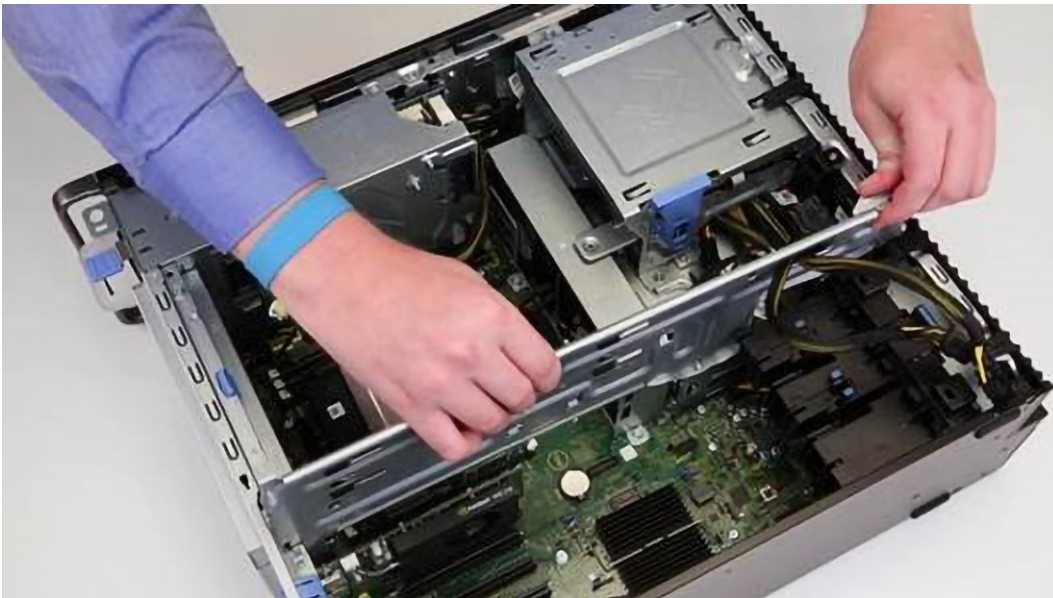

- f. Replace the screw and secure the metal separator to the chassis

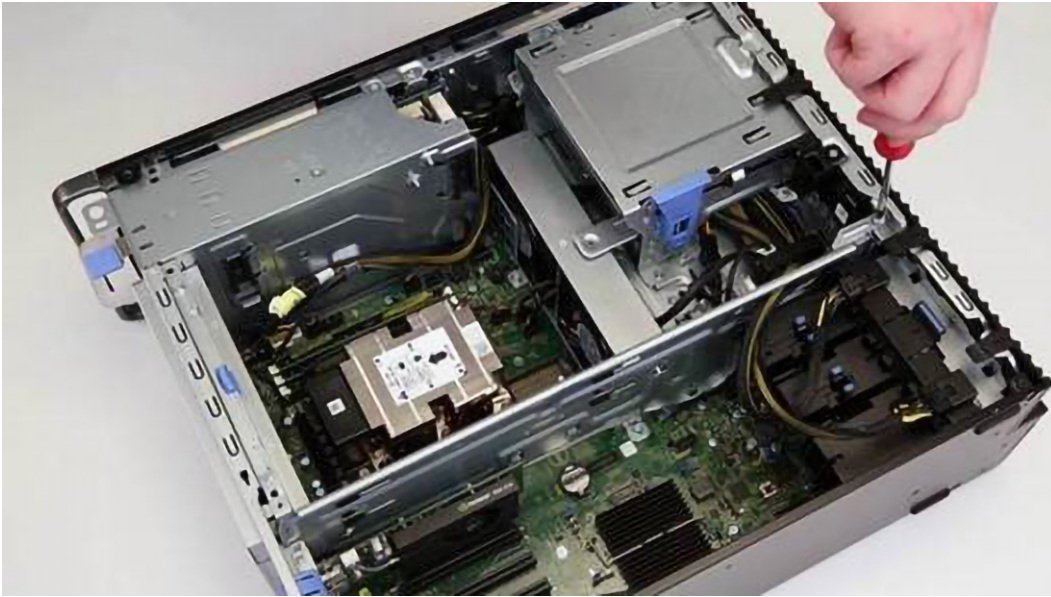

- g.** Replace the air shroud for the CPU 0

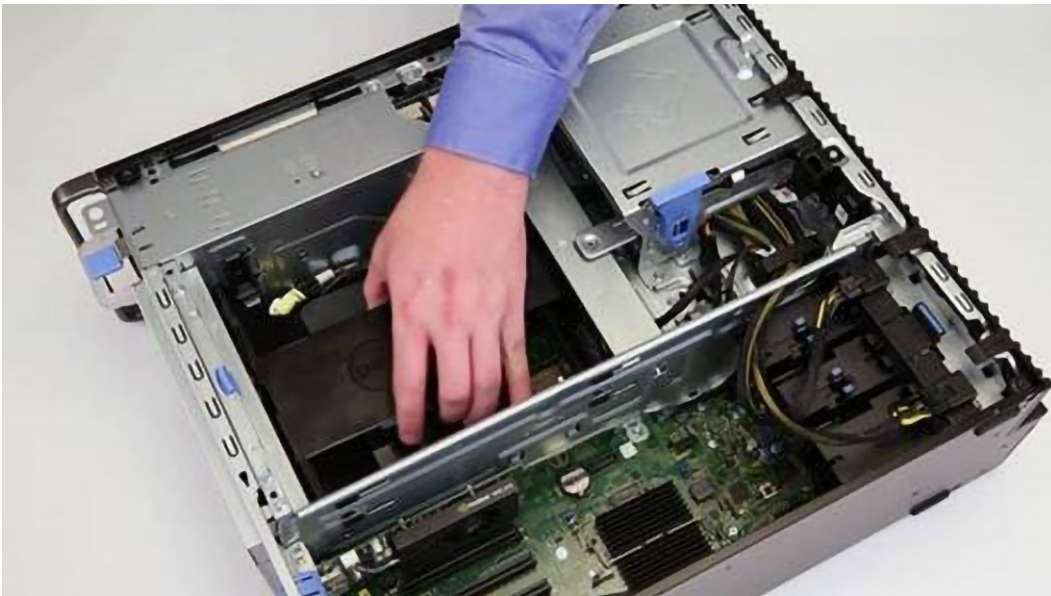

- 3.** To install the CPU1 and the riser card:
 - a.** Replace the riser card on the computer.

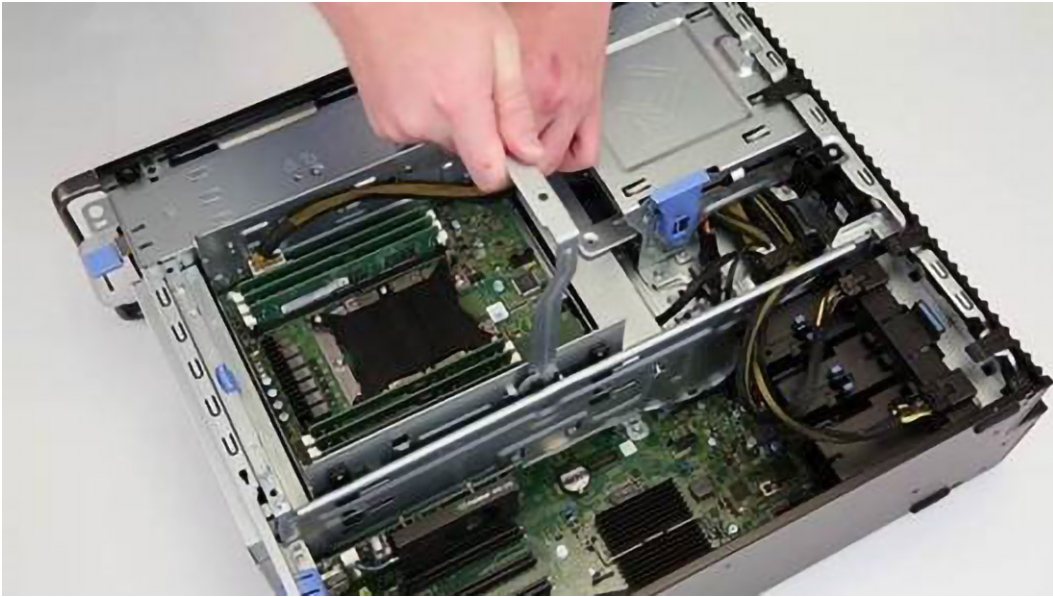

b. Press and secure the riser card latch.

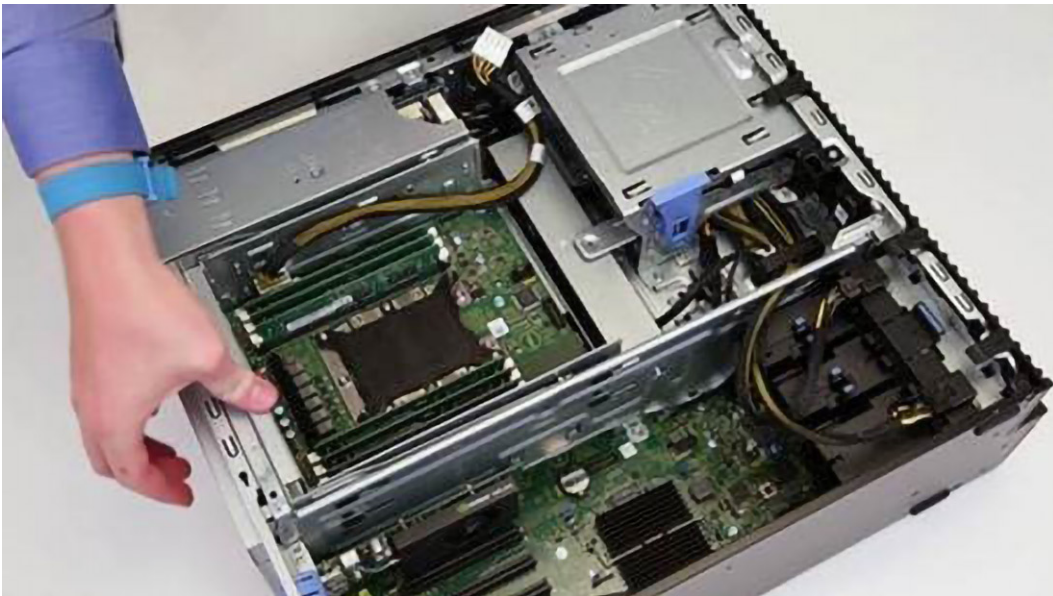

c. Connect the power cable to the riser card.

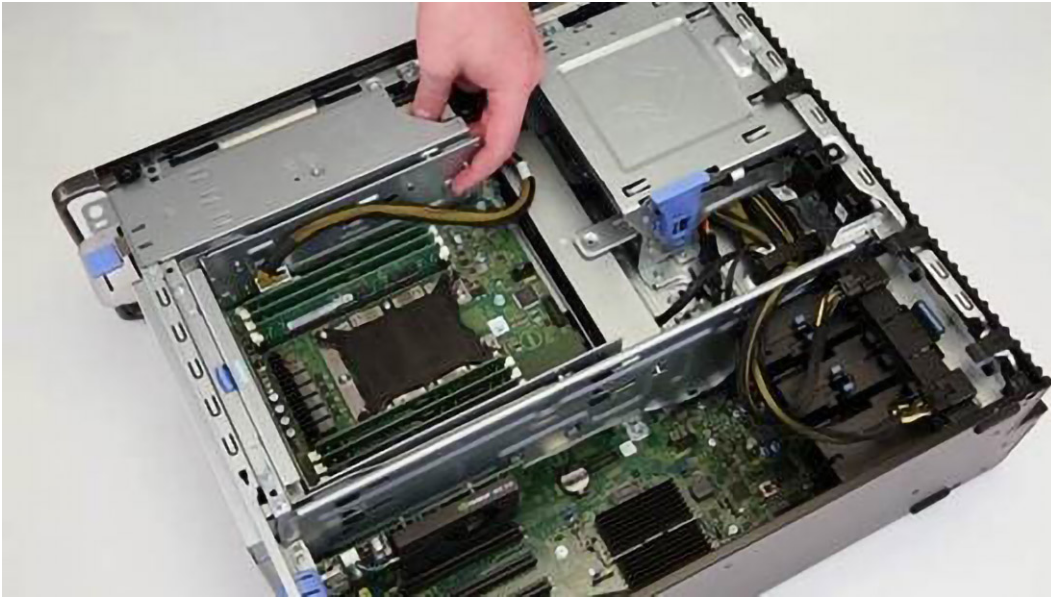

d. Install the heatsink assembly pre-assembled with the CPU1 and tighten the screws.

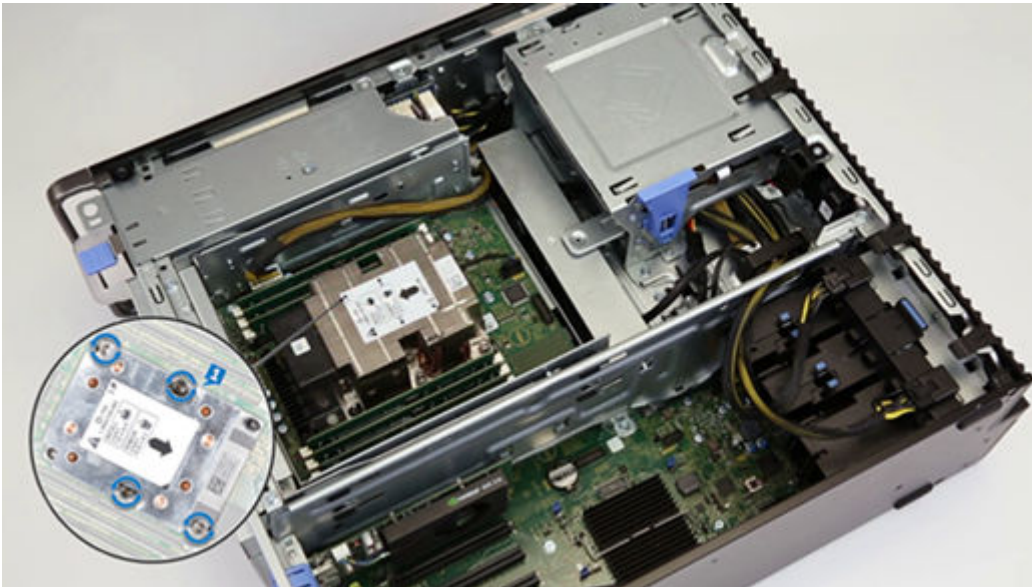

e. Install the heatsink assembly pre-assembled with the CPU1 and tighten the screws.

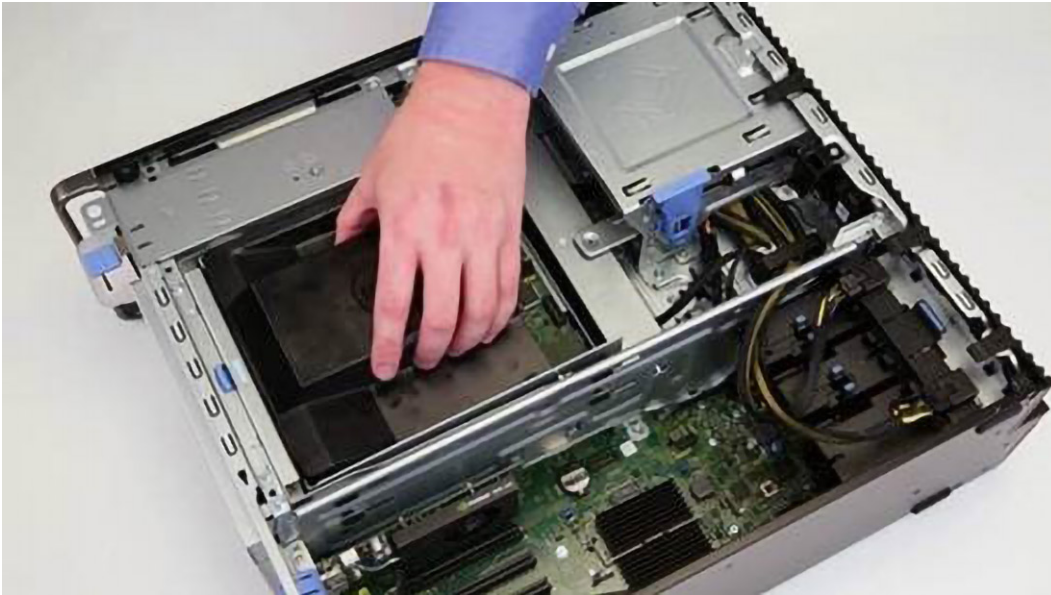

4. Install the side cover.
5. Follow the procedure in [After working inside your computer](#).

System board

Removing system board

1. Follow the procedure in [Before working inside your computer](#).
2. Remove the:
 - a. [side cover](#)
 - b. [air shroud](#)
 - c. [GPU](#)
 - d. [memory module](#)
 - e. [system fan](#)
 - f. [rear system fan](#)
 - g. [PHM](#)
 - h. [PCIe card holder](#)
3. To remove the system board:
 - a. Pull and remove the bracket [1] from the system board.
 - b. To remove the system fan fixed bracket, remove the screw [2] that secure the fixed bracket to the system board.
 - c. Lift the system fan fixed bracket from the system board [3].

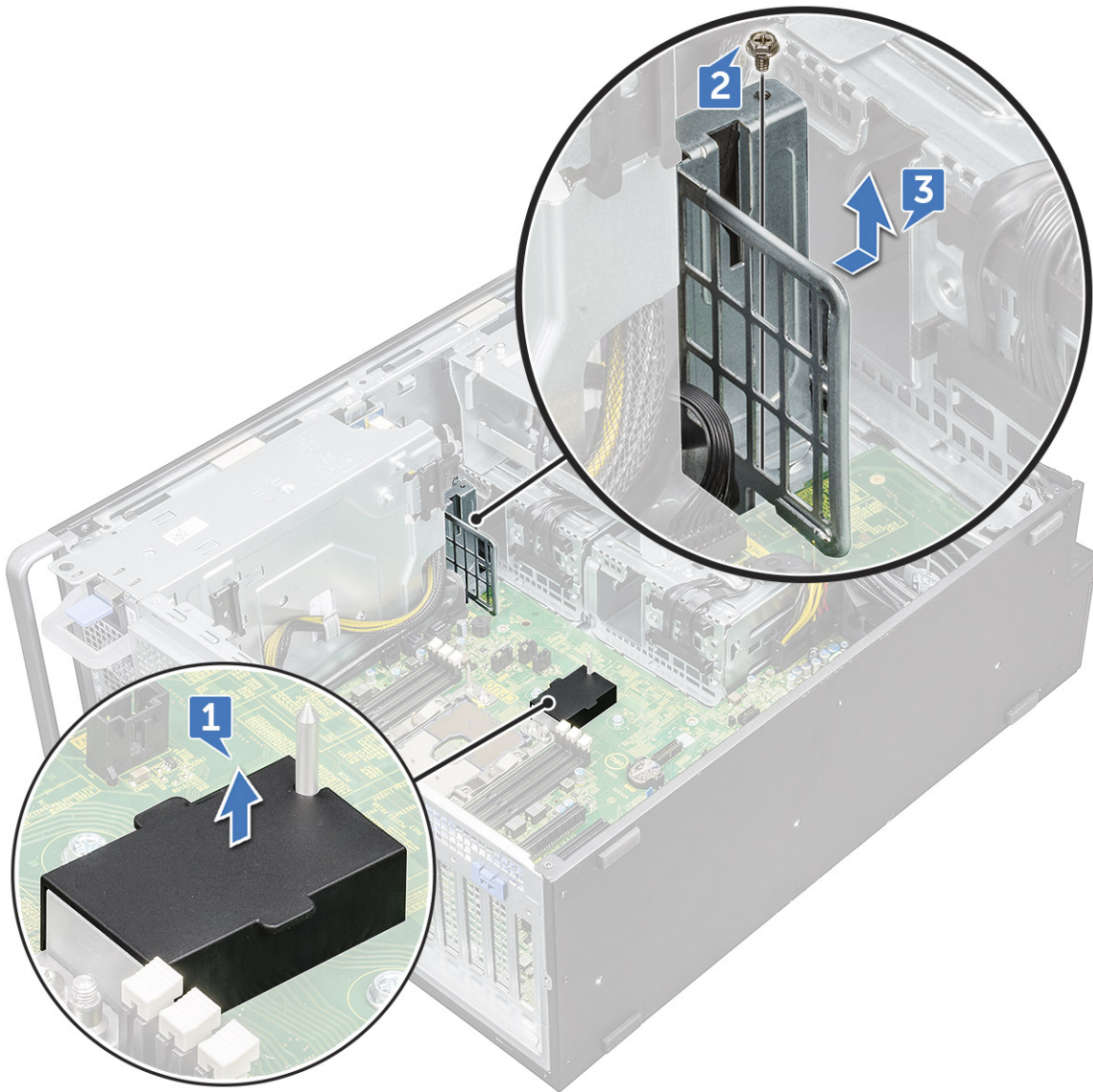

d. Disconnect the following cables from the system board connectors:

- audio cable [1]
- power cable [2]
- cable holder [3]
- power control cable [4]
- 24 Pin power cable [5]
- front I/O panel [6]

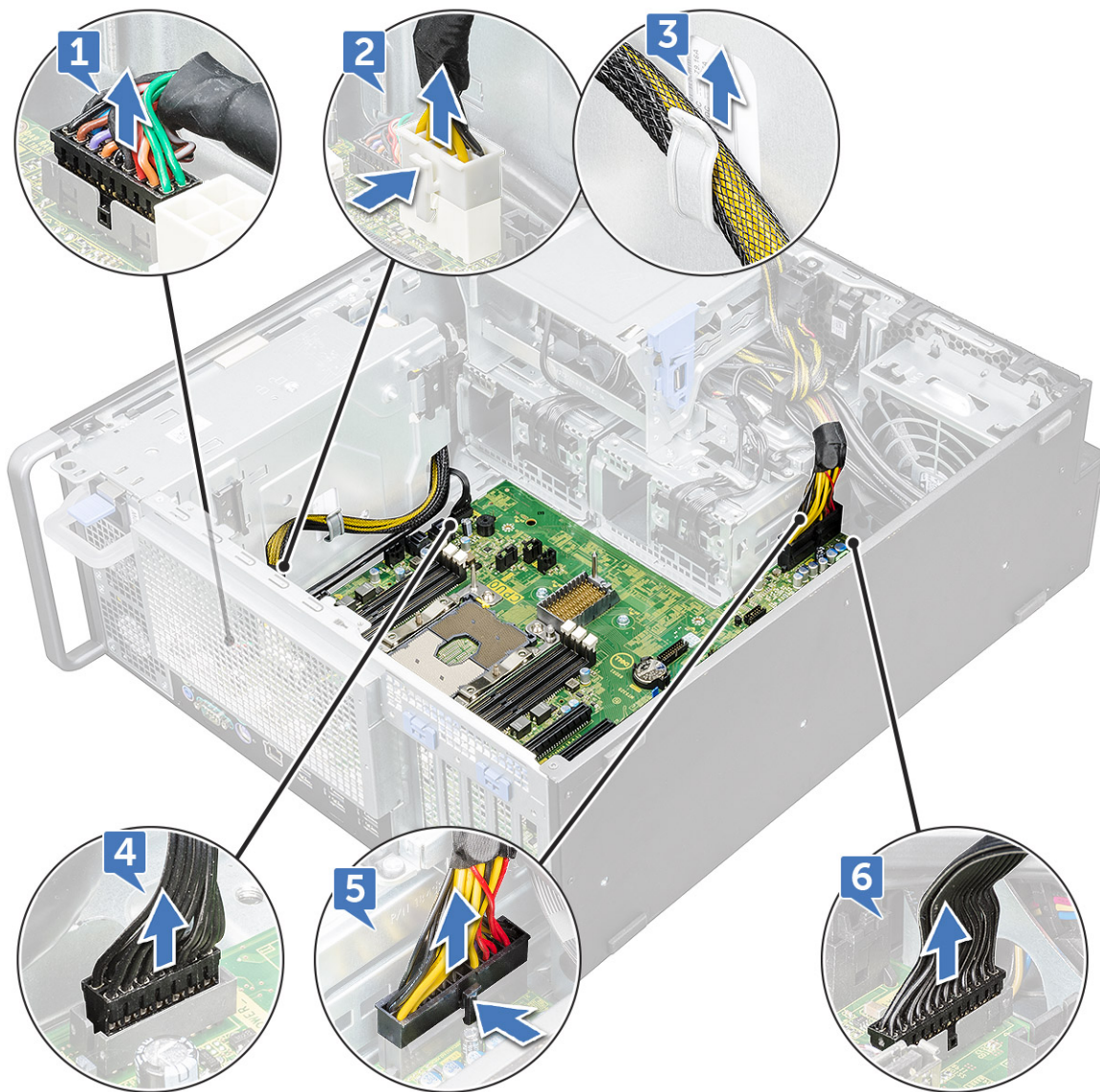

e. Disconnect the following cables:

- SATA 2, 3, 4, 5 cable [1]
- SATA 0,1 cable [2]
- ODD 0, 1 cable [3]
- USB 3.1 cable [4]
- Front system fan cable [5]

i **NOTE:** Do not pull the connector by the cable wires . Instead, disconnect the cable by pulling on the connector end.
 Pulling on the cable wires may loosen them from the connector.

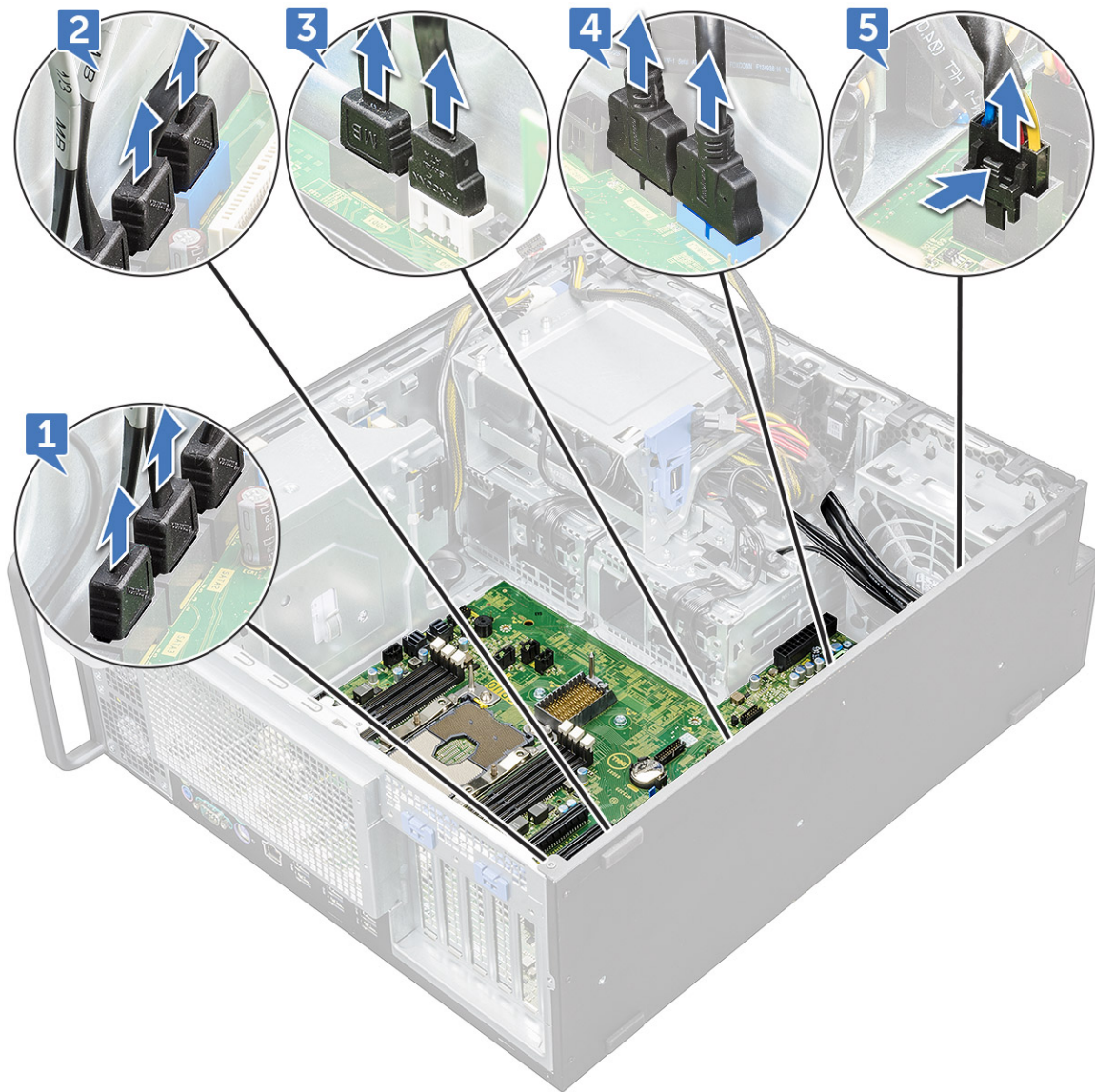

f. Remove the screws that secure the system board to the chassis.

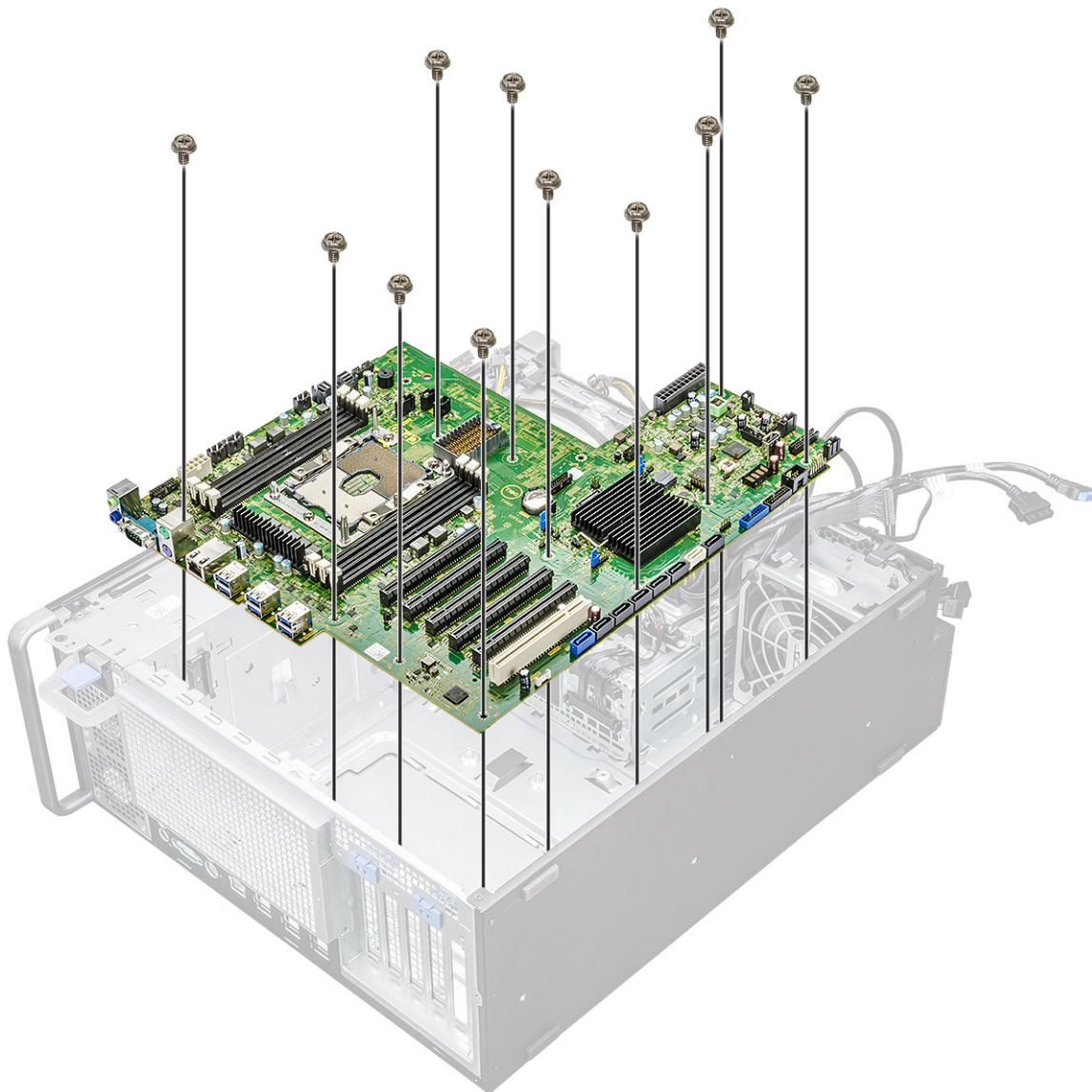

g. Slide the system board towards HDD bracket module to detach it from the system.

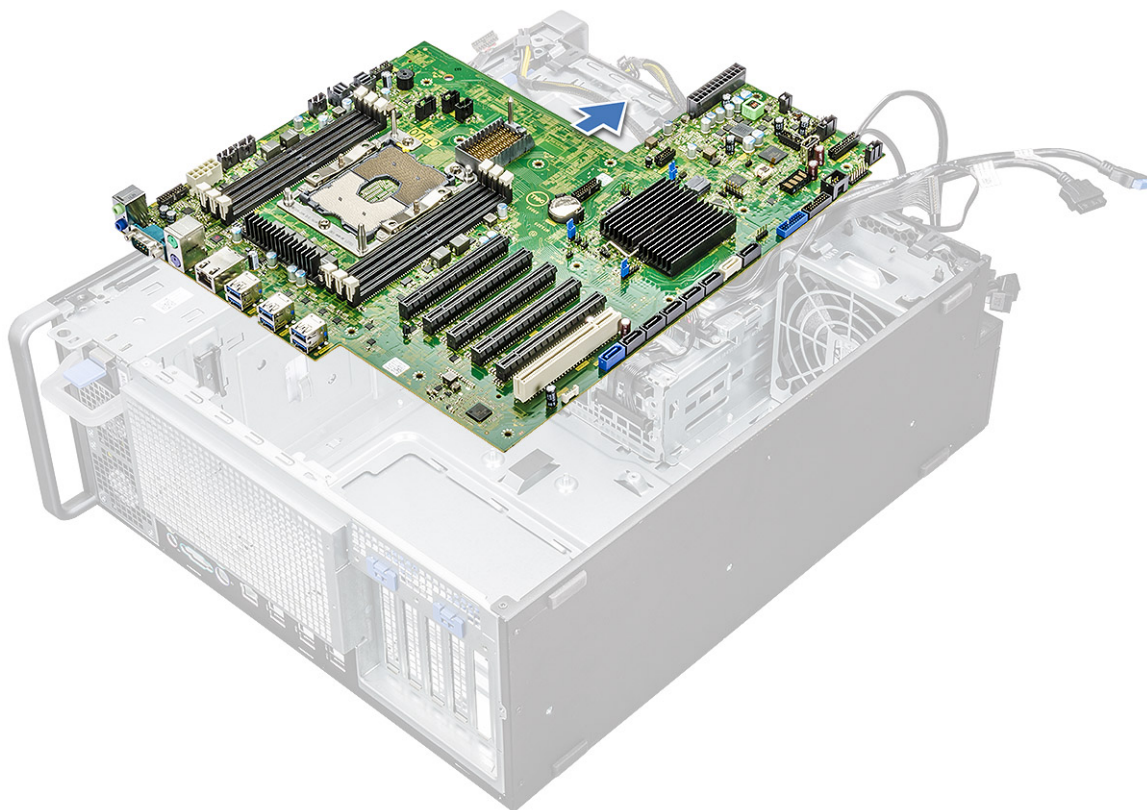

h. Lift the system board up to remove it from the chassis.

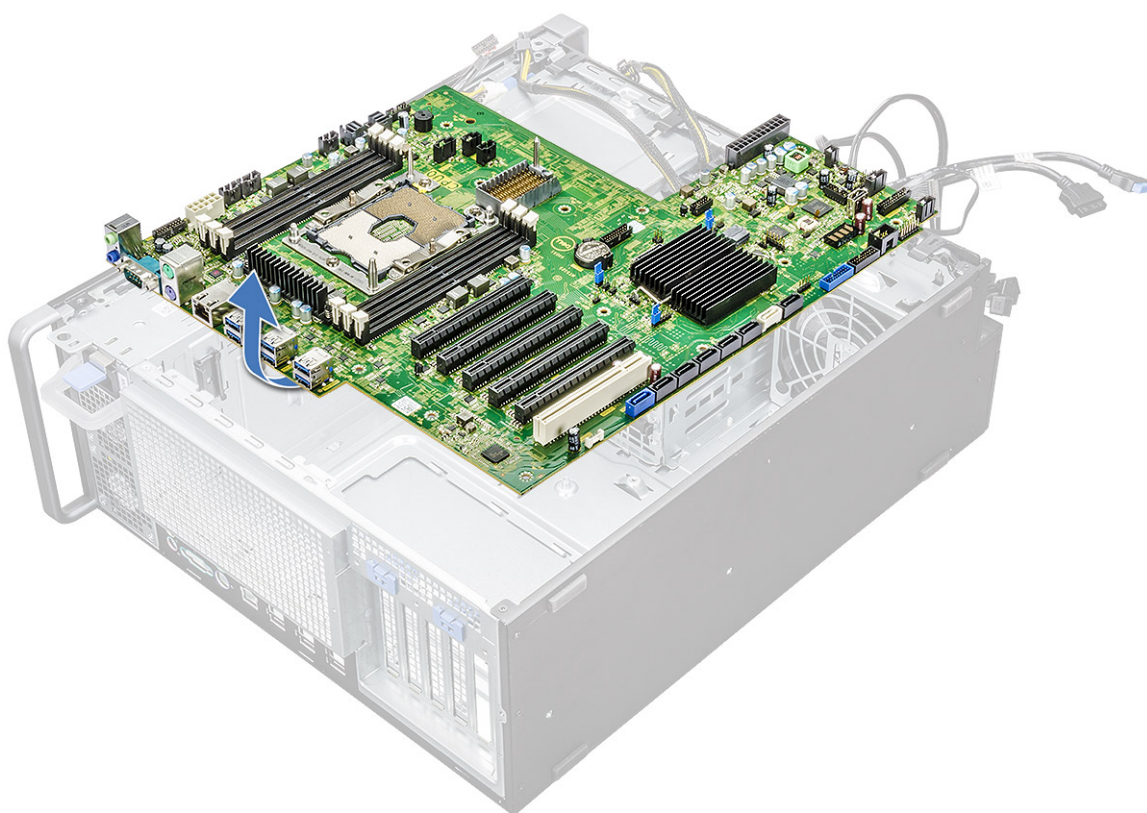

Installing the system board

1. Align and place the system board into the chassis.
2. Slide the system board to its position.
3. Replace the screws to secure the system board to the chassis.
4. Place the system fan fixed bracket and replace the single screw on the system board.
5. Connect the following cables:
 - audio cable
 - power cable
 - power control cable
 - 24 Pin power cable
 - front I/O panel
 - SATA cables
 - ODD cables
 - USB 3.1 cables
 - Front system fan cable



CAUTION: A loosely connected Power Cable (POWER_CBL) to the system board and the Power Control Cable (POWER_CTRL) may result in a No POST scenario with Diagnostics LED blinking in pattern 1,2.

6. Install the:
 - a. [PCIe holder](#)
 - b. [memory module](#)
 - c. [system fan](#)
 - d. [rear system fan](#)
 - e. [PHM](#)
 - f. [air shroud](#)
 - g. [GPU](#)
 - h. [side cover](#)
7. Follow the procedure in [After working inside your computer](#).

System board components

The following image displays the system board components.

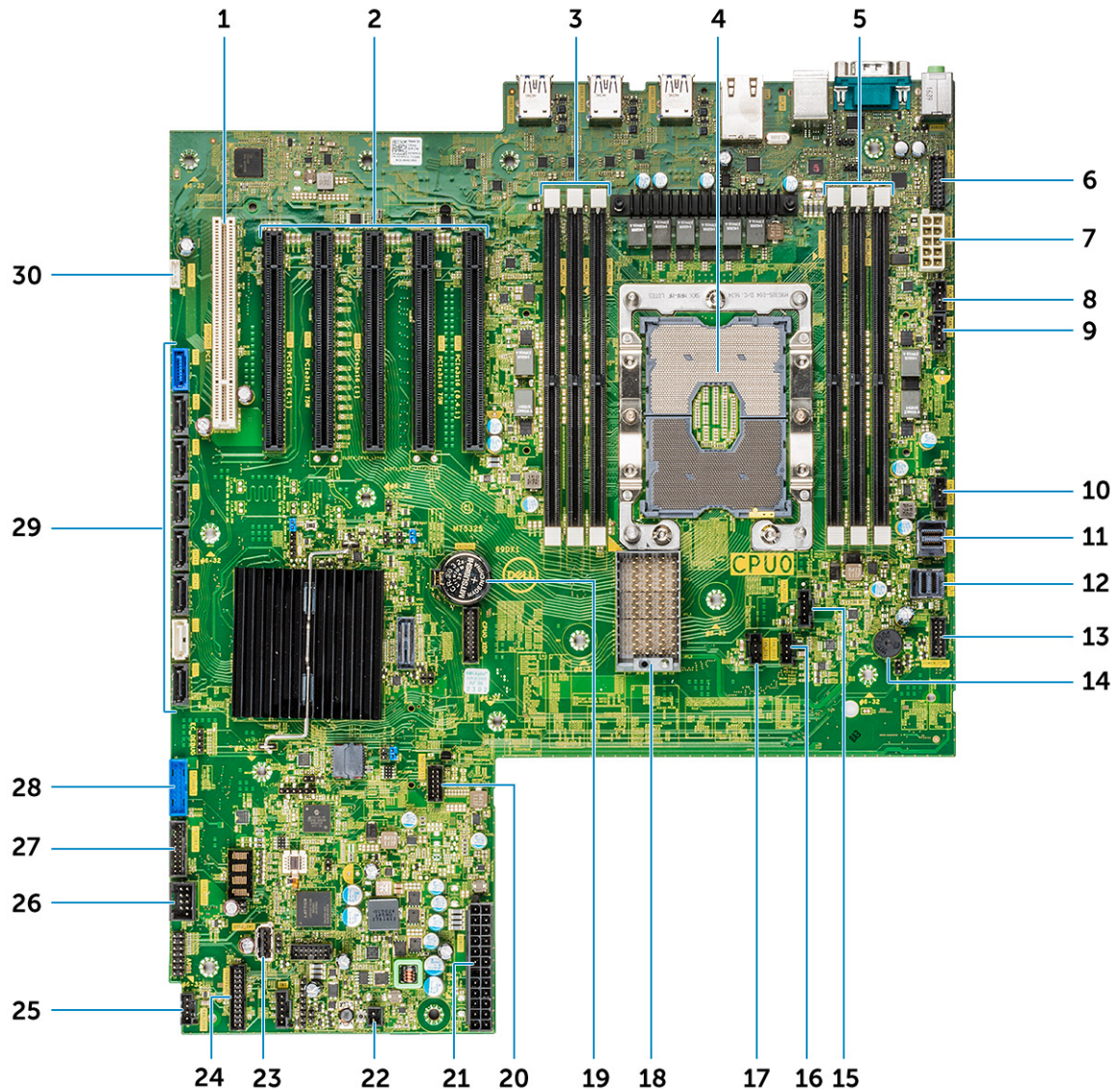

- | | |
|--|---------------------------------|
| 1. Slot 6 PCI | 2. Slot PCI 3x16 |
| 3. Memory slots | 4. CPU0 |
| 5. Memory slots | 6. Front panel audio port |
| 7. Power CPU port | 8. Rear fan 0 port |
| 9. HDD fan port | 10. Rear fan 1 port |
| 11. PCIE1 | 12. PCIE0 |
| 13. Power control port | 14. Piezo speaker |
| 15. CPU fan 0 | 16. System fan 2 |
| 17. System fan 1 | 18. CPU1 board connector |
| 19. Coin cell battery | 20. Thermal HDD port |
| 21. Power port | 22. Power remote |
| 23. USB 2_INT | 24. Front panel power connector |
| 25. System fan 0 | 26. USB 2_flex |
| 27. Front panel USB3.2 port | 28. Front panel USB3.1 |
| 29. SATA 0, 1, 2, 3, 4, 5 and ODD 0, 1 ports | 30. VROC_key |

Technology and components

This chapter details the technology and components available in the system.

Topics:

- Memory configuration
- Technologies list
- MegaRAID 9440-8i and 9460-16i controller
- Teradici PCoIP

Memory configuration

This section provides information about the memory configuration for the Dell Precision Tower 7820 systems.

DIMM slot locations

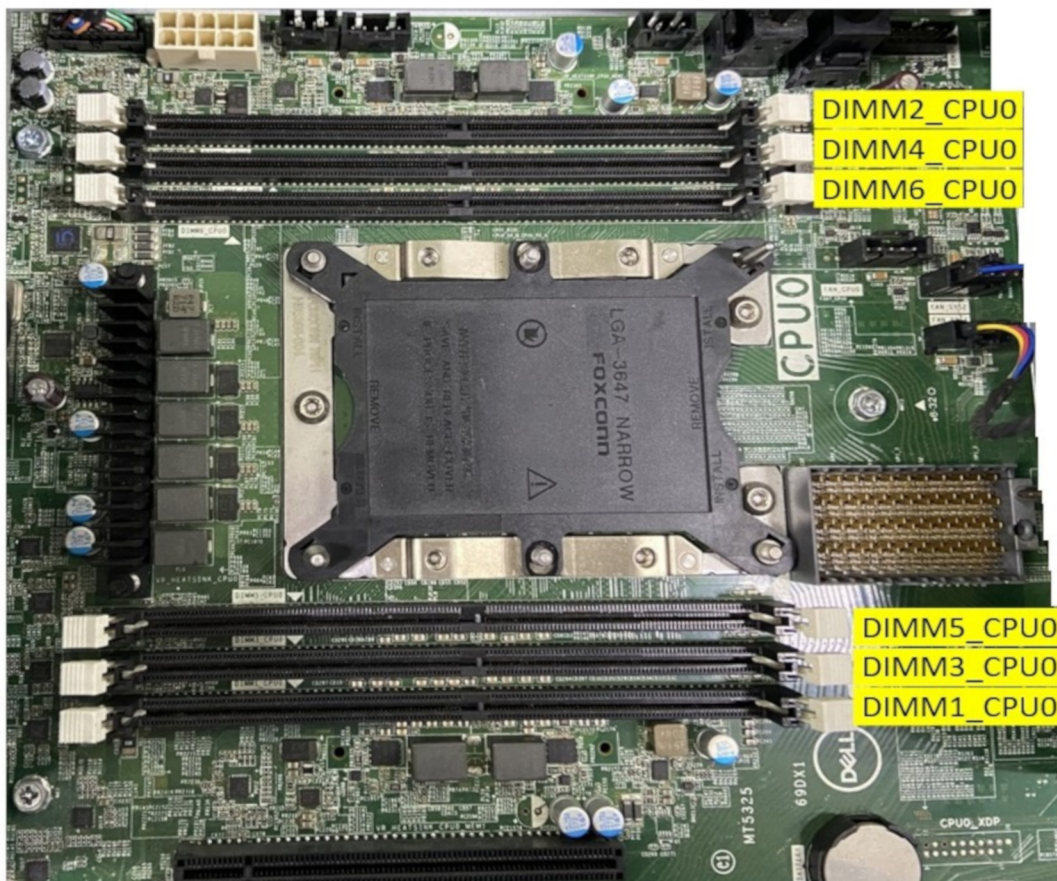

Figure 1. Single CPU configuration

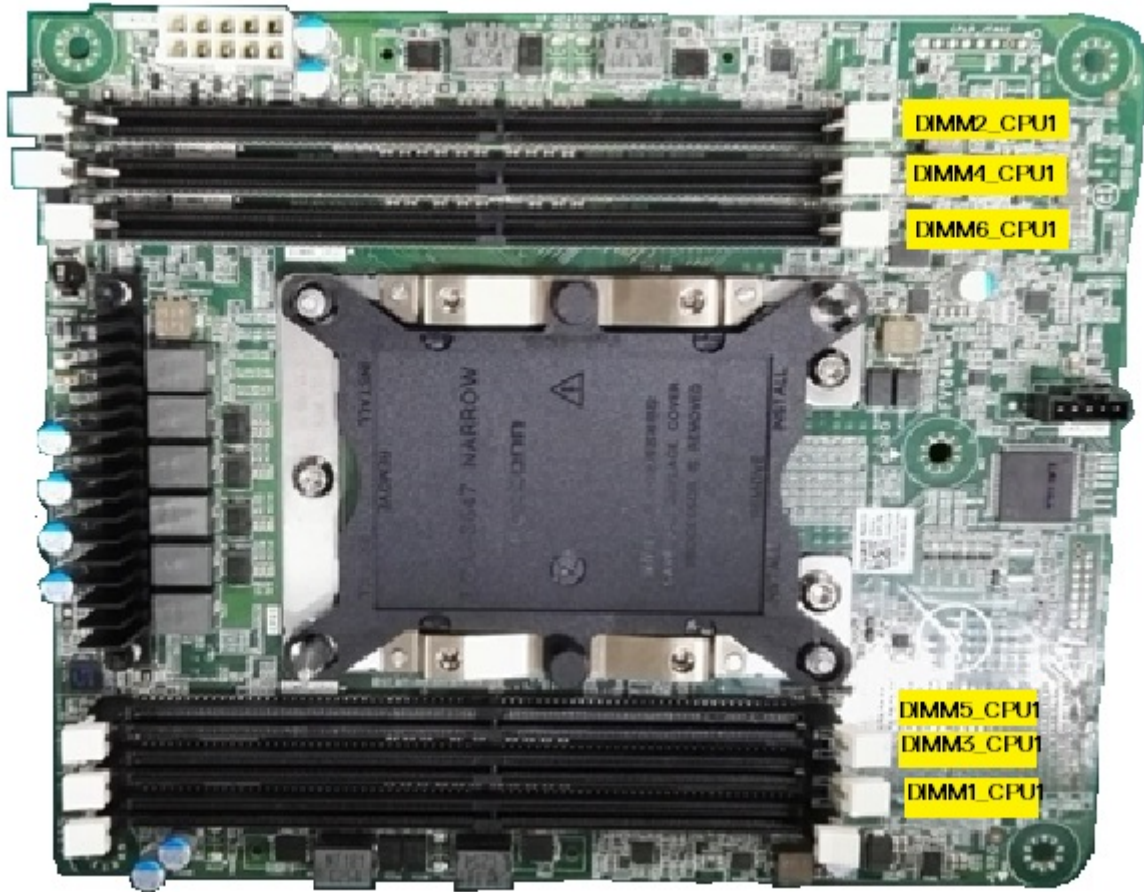

Figure 2. Dual CPU configuration

Memory Matrix

The following table illustrates the memory configuration and population rules for the Dell Precision Tower 7820:

Main Memory						CPU0																									
1LM (Main memory only)						IMC1						IMC0						IMC3						IMC2							
Config	Platform	CPU	Total (GB)	DPC	Memory physical Frequency	System running Frequency	Ch5	Ch4	Ch3	Ch0	Ch1	Ch2	Ch5	Ch4	Ch3	Ch0	Ch1	Ch2	Ch5	Ch4	Ch3	Ch0	Ch1	Ch2	Ch5	Ch4	Ch3	Ch0	Ch1	Ch2	
							0	1	0	1	0	1	0	1	0	1	0	1	0	1	0	1	0	1	0	1	0	1	0	1	
							DIMM2						DIMM2						DIMM2						DIMM2						
S8R	MS	SKL	8	1DPC	2667	2667																									
S16R	MS	SKL	16	1DPC	2667	2667																									
S32R	MS	SKL	32	1DPC	2667	2667																									
S48R	MS	SKL	48	1DPC	2667	2667																									
S64R	MS	SKL	64	1DPC	2667	2667																									
S96R	MS	SKL	96	1DPC	2667	2667																									
S192R	MS	SKL	192	1DPC	2667	2667																									
D16R	MS	SKL	16	1DPC	2667	2667																									
D32R	MS	SKL	32	1DPC	2667	2667																									
D64R	MS	SKL	64	1DPC	2667	2667																									
D96R	MS	SKL	96	1DPC	2667	2667																									
D192R	MS	SKL	192	1DPC	2667	2667																									
D384R	MS	SKL	384	1DPC	2667	2667																									
S8R	MS	CLXSKL	8	1DPC	2933	2933																									
S16R	MS	CLXSKL	16	1DPC	2933	2933																									
S32R	MS	CLXSKL	32	1DPC	2933	2933																									
S48R	MS	CLXSKL	48	1DPC	2933	2933																									
S64R	MS	CLXSKL	64	1DPC	2933	2933																									
S96R	MS	CLXSKL	96	1DPC	2933	2933																									
S192R	MS	CLXSKL	192	1DPC	2933	2933																									
S384R	MS	CLXSKL	384	1DPC	2933	2933																									
D16R	MS	CLXSKL	16	1DPC	2933	2933																									
D32R	MS	CLXSKL	32	1DPC	2933	2933																									
D64R	MS	CLXSKL	64	1DPC	2933	2933																									
D96R	MS	CLXSKL	96	1DPC	2933	2933																									
D192R	MS	CLXSKL	192	1DPC	2933	2933																									
D384R	MS	CLXSKL	384	1DPC	2933	2933																									
D768R	MS	CLXSKL	768	1DPC	2933	2933																									
S8R	MS	CLX	8	1DPC	2933	2933																									
S16R	MS	CLX	16	1DPC	2933	2933																									
S32R	MS	CLX	32	1DPC	2933	2933																									
S48R	MS	CLX	48	1DPC	2933	2933																									
S64R	MS	CLX	64	1DPC	2933	2933																									
S96R	MS	CLX	96	1DPC	2933	2933																									
S192R	MS	CLX	192	1DPC	2933	2933																									
S384R	MS	CLX	384	1DPC	2933	2933																									
D16R	MS	CLX	16	1DPC	2933	2933																									
D32R	MS	CLX	32	1DPC	2933	2933																									
D64R	MS	CLX	64	1DPC	2933	2933																									
D96R	MS	CLX	96	1DPC	2933	2933																									
D192R	MS	CLX	192	1DPC	2933	2933																									
D384R	MS	CLX	384	1DPC	2933	2933																									
D768R	MS	CLX	768	1DPC	2933	2933																									

NOTE: Here are abbreviations of the terms used in the 'Memory Matrix'-

- 'S' stands for Single CPU
- 'R' stands for RDIMM
- 'U' stands for UDIMM
- 'DPC' stands for DIMM per channel

Technologies list

This section provides information about the technologies that comes with the Dell Precision 7820 Tower.

The following table lists the basic of technologies that are available on the Dell Precision7820 Tower systems for Dell internal users only.

Table 2. Technologies list

No.	Category	Technology	Browser Path
1	Chipset	Intel C620 Series Chipset (C621)	
2	Processor	<ul style="list-style-type: none"> Intel Xeon Platinum 81xx Processor Intel Xeon Gold 61xx Processor Intel Xeon Gold 51xx Processor 	

Table 2. Technologies list (continued)

No.	Category	Technology	Browser Path
		<ul style="list-style-type: none"> • Intel Xeon Silver 41xx Processor • Intel Xeon Bronze 31xx Processor • Intel Xeon Gold 52xx processors • Intel Xeon Silver 42xx processors • Intel Xeon Bronze 32xx processors • Intel Xeon Platinum 82xx processors • Intel Xeon Gold 62xx processors 	
3	Memory	DDR4	
4	Audio	Integrated Realtek ALC3234 High Definition Audio Codec (2 Channel)	
5	Network	NIC Integrated RJ45	
6	Graphics	Radeon Pro WX	<ul style="list-style-type: none"> • 9100 • 7100 • 5100 • 4100 • 3100 • 2100 • 3200
		NVIDIA	<ul style="list-style-type: none"> • Quadro GP100 • Quadro P6000 • Quadro P5000 • Quadro P4000 • Quadro P2000 • Quadro P1000 • Quadro P600 • Quadro P400 • Quadro 8000 • Quadro 2200 • Quadro P620 • Quadro GV100 • NVS 310 • NVS 315 • Quadro RTX 4000 • Quadro RTX 5000/6000 • GEFORCE RTX 2080 B • NVIDIA GEFORCE RTX 3080 • NVIDIA GEFORCE RTX 3090
7	Storage	SATA	
		SAS	
		Dell UltraSpeed Quad (PCIE M.2 Interposer)	
		Dell UltraSpeed Duo (PCIE M.2 Interposer)	

Table 2. Technologies list (continued)

No.	Category	Technology	Browser Path
9	Remote Solutions	1-1 Teradici PCoIP	<ul style="list-style-type: none"> CLIENT: Dell or other Branded Zero Client (TERA Gen 2) (Dell-Wyse P25) DUAL Monitor Support HOST: PCIe x1 PCoIP Dual Host Card (TERA Gen 2) CLIENT: Dell or other Branded Zero Client (TERA Gen 2) (Dell-Wyse P45) QUAD Monitor Support HOST: PCIe x1 PCoIP Quad Host Card (TERA Gen 2) Support Dual Terra Card configurations <p>i NOTE: For further information about the Teradici PCoIP Card host driver installation, see Teradici PCoIP.</p>

MegaRAID 9440-8i and 9460-16i controller

Small and medium businesses (SMBs) deploying entry-level server platforms and workstations need affordable, reliable storage solutions. The MegaRAID Tri-Mode Storage Adapter is a 12Gb/s SAS/SATA/PCIe (NVMe) controller card that addresses these needs by delivering proven performance and RAID data protection for a range of non-business critical applications. The MegaRAID Tri-Mode storage adapters bring NVMe performance benefits to the storage tier by providing connectivity and data protection for SAS/SATA interfaces. Based on the dual-core SAS3516 or SAS3508 RAID on Chip (ROC) and 72-bit DDR4-2133 SDRAM, these controllers provide bandwidth and IOPS performance increases and are ideal for high-end servers utilizing

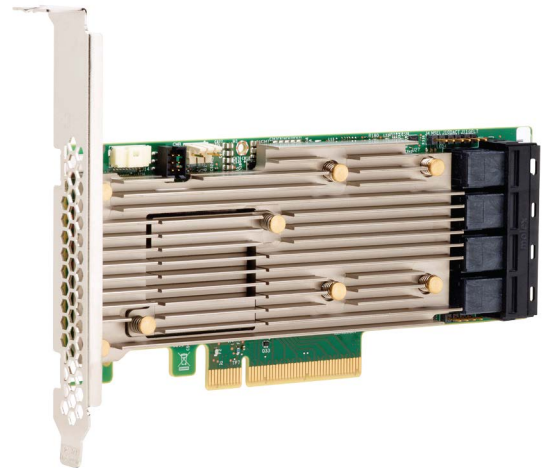

internal storage or connecting to large-scale external storage enclosures.

i **NOTE:** The MegaRAID 9440 and 9460 controllers are supported when using Intel Xeon CPUs on 7820, 7920 Towers or Intel Xeon W Series CPUs on 5820 Tower.

Tri-Mode SerDes Technology enables operation of NVMe, SAS, or SATA storage devices in a single drive bay. All the 3 modes concurrently serving NVMe, SAS, and SATA drives can be operated by a single controller. The controller negotiates between the speeds and protocols to seamlessly work with any of the three types of storage devices. Tri-Mode support provides a non-disruptive way to evolve existing data center infrastructure. By upgrading to a tri-mode controller, users can expand beyond SAS/SATA and use NVMe without major changes to other system configurations. The MegaRAID Tri-Mode storage adapters support both REFCLK and SRIS based NVMe x1, x2, and x4 devices.

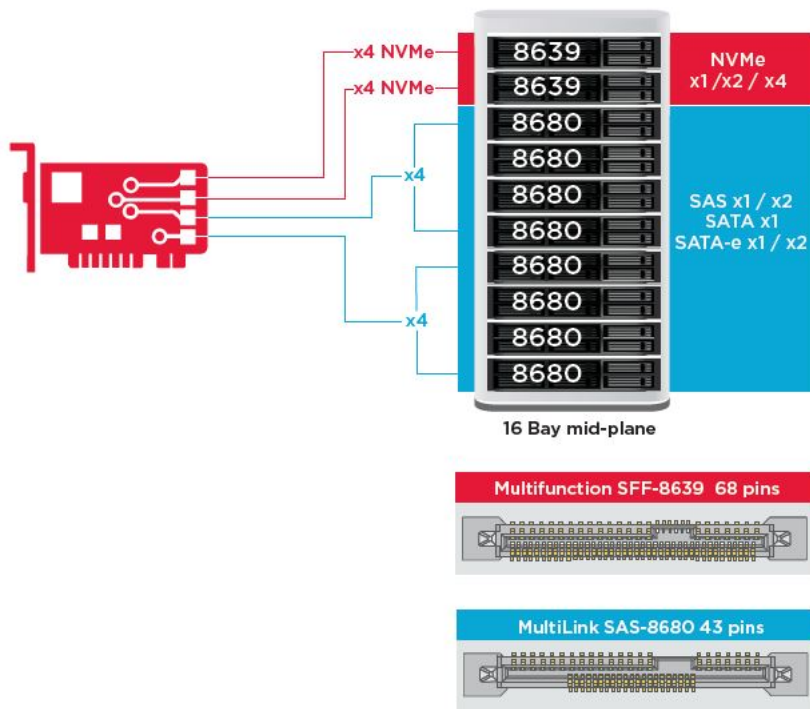

Key Features:

- Tri-Mode SerDes Technology enables the operation of NVMe, SAS or SATA devices in a single drive bay, allowing for endless design flexibility
- Supports 12, 6, and 3 Gb/s SAS and 6, 3 Gb/s SATA data transfer rates
- Up to 8 PCIe links. Each link supporting x4, x2, or x1 link widths, supporting 8.0 GT/s (PCIe Gen3) per lane
- SFF-9402 Compliant, Connector Pin-out
- SFF-8485 Compliant, SGPIO
- Fits into rack-mounted servers with low-profile form factor and side-mounted SAS connectors
- Support critical, high-bandwidth applications with PCIe 3.1 connectivity
- CacheVault flash back-up at power fail. Supports bad block management
- Balance protection and performance for critical applications with RAID levels 0, 1, 5, 6, 10, 50, and 60

Table 3. Features of MegaRAID 9440-8i and 9460-16i controller

	9440-8i	9460-16i
Ports	8 internal	16 internal
Connectors	2 x SFF8643	4 x SFF8643 x4
Storage Interface Support	SATA: Eight x1 SAS: One x8, Two x4, Four x2, Eight x1 NVMe: Two x4, Four x2, Four x1	SATA: Sixteen x1 SAS: Two x8, Four x4, Eight x2, Sixteen x1 NVMe: Four x4, Eight x2, Eight x1
Max Devices Per Controller	SAS/SATA: 64 NVMe: 4	SAS/SATA: 240 NVMe: 24
Cache Memory	N/A	4 GB 2133 MHz DDR4 SDRAM
I/O Processor / SAS Controller	SAS3408	SAS3516
Host Bus Type	PCIe 3.1 x8	PCIe 3.1 x8

Table 3. Features of MegaRAID 9440-8i and 9460-16i controller (continued)

	9440-8i	9460-16i
Cache Protection	N/A	CacheVault CVPM05
Physical Dimensions	6.127" x 2.712" (155.65 mm x 68.90 mm)	6.127" x 2.712" (155.65 mm x 68.90 mm)
Maximum Operating Conditions	Operating: 10°C to 55°C 20 to 80% non-condensing Airflow: 300 LFM Storage: -45°C to 105°C 5 to 90% non-condensing	Operating: 10°C to 55°C 20 to 80% non-condensing Airflow: 300 LFM Storage: -45°C to 105°C 5 to 90% non-condensing
MTBF (Calculated)	>3,000,000 hours at 40C	>3,000,000 hours at 40C
Operating Voltage	+12V +/-8%; 3.3V +/-9%	+12V +/-8%; 3.3V +/-9%
Hardware Warranty	3 years; with advanced replacement option	3 years; with advanced replacement option
MegaRAID Management Suite	LSI Storage Authority (LSA) StorCLI (command-line interface), CTRL-R (BIOS configuration utility), HII (UEFI Human Interface Infrastructure)	LSI Storage Authority (LSA) StorCLI (command-line interface), CTRL-R (BIOS configuration utility), HII (UEFI Human Interface Infrastructure)
Regulatory Certifications	USA (FCC 47 CFR part 15 Subpart B, class B); Canada (ICES -003, Class B); Taiwan (CNS 13438); Japan (VCCI V-3); Australia/New Zealand (AS/NZS CISPR 22); Korea (RRA no 2013-24 & 25); Europe (EN55022/EN55024); Safety: EN/IEC/UL 60950; RoHS; WEEE	USA (FCC 47 CFR part 15 Subpart B, class B); Canada (ICES -003, Class B); Taiwan (CNS 13438); Japan (VCCI V-3); Australia/New Zealand (AS/NZS CISPR 22); Korea (RRA no 2013-24 & 25); Europe (EN55022/EN55024); Safety: EN/IEC/UL 60950; RoHS; WEEE
OS Support	Microsoft Windows, VMware vSphere/ ESXi, Red Hat Linux, SuSe Linux, Ubuntu Linux, Oracle Linux, CentOS Linux, Debian Linux, Fedora, and FreeBSD. Contact Oracle support for Oracle Solaris driver or software support.	Microsoft Windows, VMware vSphere/ ESXi, Red Hat Linux, SuSe Linux, Ubuntu Linux, Oracle Linux, CentOS Linux, Debian Linux, Fedora, and FreeBSD. Contact Oracle support for Oracle Solaris driver or software support.

Teradici PCoIP

This section provides an overview of the host driver installation process.

Installing the Teradici PCoIP Card Host Dual/Quad

Install the PCoIP host driver software from dell.com/support.

NOTE: You cannot upgrade the PCoIP host driver software while a VMware View-brokered PCoIP session is active between a host workstation or host PC and VMware View client. Doing this will result in losing access to your mouse and keyboard when the driver software is removed.

To upgrade the PCoIP host driver software in this type of deployment, do one of the following:

- Connect to the host from a zero client.

- Upgrade the software while connecting to the host through another desktop-remoting protocol such as RDP or VNC.

Installing the PCoIP Host Driver Software on a Host PC:

1. Download the PCoIP host driver software from the Teradici Support site (click Current PCoIP Product and Releases).
2. Log in to the administrative web interface for the host card.
3. From the **Configuration > Host Driver Function** menu, enable the Host Driver Function.
4. Restart the host PC.
5. Install the PCoIP host software package appropriate for the operating system installed on the host PC. You can start the install process by double-clicking the installer:
 - a. 64 bit: PCoipHostSoftware_x64-v4.3.0.msi (or later)
6. When the Welcome screen appears, click **Next**.
7. Accept the terms, and then click **Next**.
8. Ensure that the installation location is correct, and click **Next**.
9. Click **Install**.

i **NOTE:** For Windows 7, when the driver is installed, a Windows Security dialog may appear. Click **Install** to continue with the installation. To keep this dialog box from appearing in the future, select **Always trust software from Teradici Corporation**.
10. If prompted, restart the operating system; otherwise, skip this step. When restarted, the host driver software installation process continues when the OS boots up. Click **Install** to continue.
11. Click **Finish** to complete the installation.

Power management cable configuration for Teradici PCoIP Portal and Host Card

If the Dell Precision Workstation comes equipped with the optional Teradici PCoIP Portal and Host Card, make sure the power management cable on the Teradici card is connected properly on the system board. The power management cable from the Teradici card must be plugged into the correct Power remote connection on the system board.

Refer the below image for an example of the **Power remote** connector labeled 22 on the system board diagram:

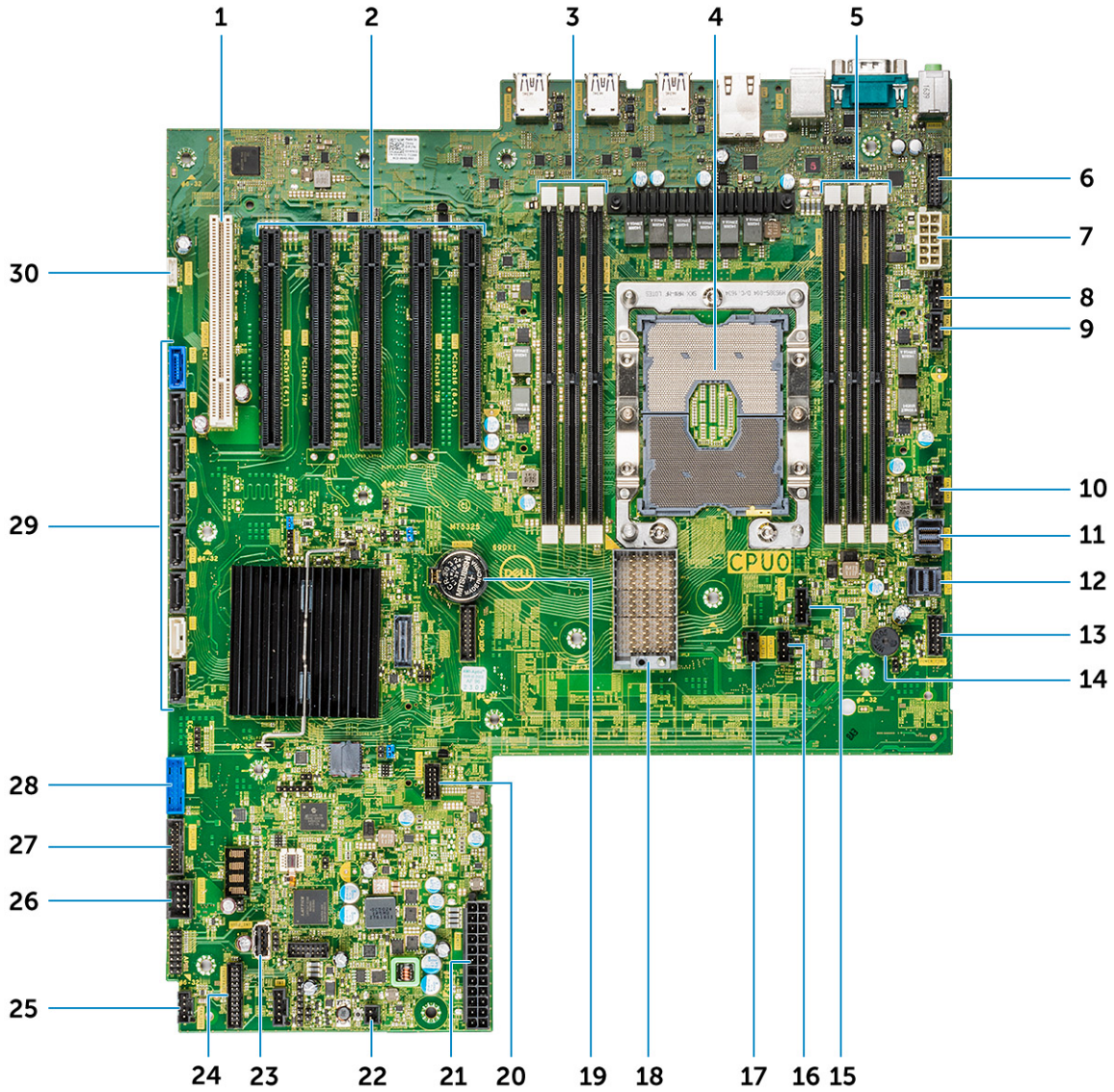

Make sure the power management cable from the Teradici card is not plugged into either the two-pin Clear CMOS or Clear PSWD jumpers.

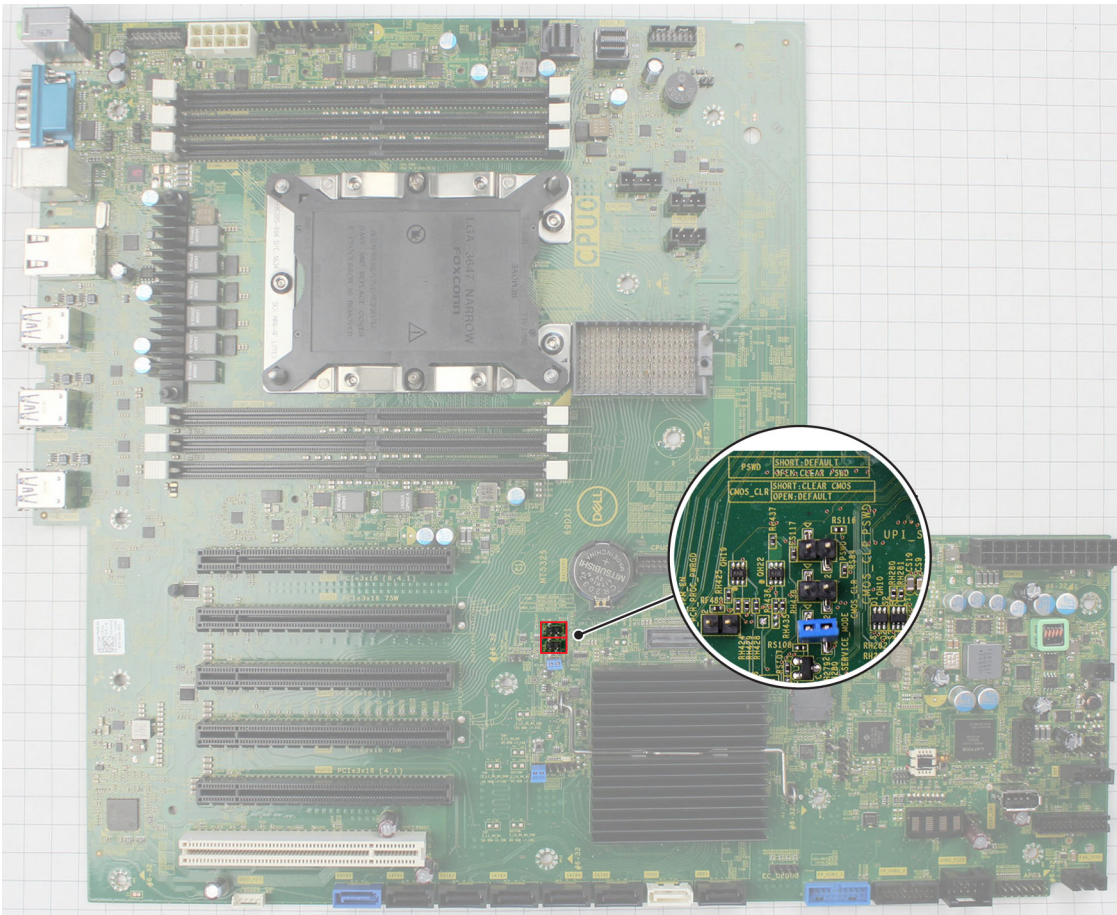

Plugging the power management cable into the Clear CMOS jumper will cause the BIOS to reset when sending a remote restart request to the Teradici card. You will then have to reset the time and BIOS settings.

If the power management cable from the Teradici card is plugged into the Clear PSWD jumper, then the BIOS password will be cleared and a new one will need to be configured.

System specifications

Topics:

- System specifications
- Memory specifications
- Video specifications
- Audio specifications
- Network specifications
- Card slots
- Storage specifications
- External connectors
- Power specifications
- Physical specifications
- Environmental specifications
- CPU utilization matrix for AEP DIMM

System specifications

Feature	Specification
Processor type	<ul style="list-style-type: none"> • Intel Xeon Platinum 81xx processors • Intel Xeon Gold 51xx processors • Intel Xeon Gold 61xx processors • Intel Xeon Silver 41xx processors • Intel Xeon Gold 52xx processors • Intel Xeon Silver 42xx processors • Intel Xeon Bronze 32xx processors • Intel Xeon Platinum 82xx processors • Intel Xeon Gold 62xx processors
Total cache	Upto 38.5 MB

Memory specifications

Features	Specifications
Type	<ul style="list-style-type: none"> • DDR4 ECC RDIMMs - Supported only with Xeon W Series CPUs • DDR4 Non-ECC UDIMMs supported with Core X Series CPUs
Speed	<ul style="list-style-type: none"> • 2666 MHz • 2933 MHz • 3200 MHz <p>i NOTE: 2933 MHz RDIMMs are not offered with Xenon W Skylake Series CPUs.</p> <p>i NOTE: Computer configurations offered with 2933 MHz RDIMMs operating with Sky Lake processors will operate at 2666 MHz.</p> <p>i NOTE: Computer configurations offered with 3200 MHz RDIMMs operating with Cascade Lake processors will operate at 2933 MHz.</p>

Features	Specifications
Connectors	6 DIMM Slots  NOTE: For computers shipped with dual CPU configuration, 6 more memory connectors for the second CPU are available on the Riser card.
Capacity	<ul style="list-style-type: none"> • 32 GB per slot 2666 MHz DDR4 • 64 GB per slot 2933 MHz DDR4 • 64 GB per slot 3200 MHz DDR4
Maximum memory	<ul style="list-style-type: none"> • 256 GB for Sky Lake Series CPUs • 512 GB for Cascade Lake Series CPUs

 **NOTE:** Intel Optane persistent memory (PMem) is supported on this system.

Video specifications

Features	Specifications
Graphic card	<ul style="list-style-type: none"> • Radeon Pro WX 9100 • NVIDIA Quadro GP100 • NVIDIA Quadro P6000 • NVIDIA Quadro P5000 • Radeon Pro WX 7100 • Radeon Pro WX 5100 • Radeon Pro WX 4100 • NVIDIA Quadro P4000 • NVIDIA Quadro P2000 • Radeon Pro WX 3100 • Radeon Pro WX 2100 • NVIDIA Quadro P1000 • NVIDIA Quadro P600 • NVIDIA Quadro P400 • NVIDIA Quadro T400 • NVIDIA Quadro T600 • NVIDIA Quadro T1000 • NVIDIA NVS 310 • NVIDIA NVS 315 • NVIDIA Quadro RTX 4000 • NVIDIA Quadro RTX 5000/6000 • NVIDIA GEFORCE RTX 2080 B • NVIDIA GEFORCE RTX 3080 • NVIDIA GEFORCE RTX 3090  NOTE: NVIDIA GEFORCE RTX 3080 and 3090 Graphics cards are qualified to be used on the slot 2 and slot 4, PCIe slot of the system board.

Audio specifications

Features	Specifications
Type	High Definition Audio Codec (2 Channel)
Controller	Integrated Realtek ALC3234
Internal Speaker Power Rating	2W

Features	Specifications
----------	----------------

Internal microphone support	no
------------------------------------	----

Network specifications

Features	Specifications
----------	----------------

Integrated	Intel i219 Gigabit Ethernet controllers with Intel Remote Wake UP, PXE and Jumbo frames support
-------------------	---

Optional	<ul style="list-style-type: none">• Intel i210 10/100/1000 single port PCIe (Gen 1 x 1) gigabit network card.• Intel X550-T2 10GbE dual port PCIe (Gen 3 x 4) network card• Aquantia AQN-108 2.5Gbit/5Gbe single port PCIe (Gen 3 x 4) network card.• Intel X710-T2L-t 10GbE dual port PCIe (Gen 3 x8) network card.
-----------------	--

NOTE: Wake on LAN (WoL) is not supported on the Intel X550-T2 network card and the Intel X710-T2L-t network card.

Card slots

Features	Specifications
----------	----------------

Type	PCIe Gen 3
-------------	------------

Slots	<ul style="list-style-type: none">• 2 PCIe x 16• 1 PCIe x 16 wired as x8• 1 PCIe x 16 wired as x4• 1 PCIe x 16 wired as x1• 1 PCI 32/33
--------------	---

NOTE: For technical reasons, it is required that the Qualcomm WCN6856-DBS Wi-Fi/Bluetooth Card be installed in PCIe Slot 5 on the system board

Storage specifications

Features	Specifications
----------	----------------

Externally Accessible	DVD-ROM; DVD+/-RW 5.25" Bay Options: BD, DVD+/-RW
------------------------------	---

Internally Accessible	<ul style="list-style-type: none">• M.2 NVMe PCIe SSDs — Up to 4 x 1 TB drives on 1 Dell Precision Ultra-Speed Drive Quad x16 cards• Front FlexBay M.2 NVMe PCIe SSDs —Up to 2 x 1 TB drives• Up to 6 x 2.5" SATA drives• Up to 5 x 3.5" SATA drives• Slim ODD• SAS available with optional controller• Total possible SATA storage—60 TB made up of 5 x 3.5" SATA drives with a storage capacity of 12 TB per drive.
------------------------------	---

External connectors

Features	Specifications
Audio	<ul style="list-style-type: none">• Rear—1 x Audio Line in/Microphone• Rear—1 x Audio Line out• Front—1 x Universal Audio Jack
Network	Rear—1 x RJ45 Network
USB	<ul style="list-style-type: none">• Front—4 x USB 3.1 Gen1• Rear—6 x USB 3.1 Gen1
Serial port	Rear—1 x Serial port
PS2	<ul style="list-style-type: none">• Rear—1 x Keyboard• Rear—1 x Mouse

Power specifications

Features	Specifications
Wattage	950 W
Voltage	input voltage 100 VAC-240 AC

Physical specifications

Features	Specifications
Height	417.9 mm
Width	176.5 mm
Depth	<ul style="list-style-type: none">• 518.3 mm
Optional	19" rackmount rail kit

Environmental specifications

Temperature	Specifications
Operating	5 °C to 35 °C (41 F to 95 °F)  NOTE: * Starting at 5000 ft, the maximum operating ambient temperature is derated by 1 C (1.8 F) per 1000 ft up to 10,000 ft.
Storage	-40 °C to 65 °C (-40 F to 149 F)
Relative humidity (maximum)	Specifications
Operating	8% to 85% (non-condensing)
Storage	5% to 95% (non-condensing)

Maximum vibration

Specifications

Operating 0.52 Grms, 5 to 350 Hz

Storage 2.0 Grms, 5 to 500 Hz

Maximum Shock

Specifications

Operating 40 G half-sine 2.5 ms pulse

Storage 105 G half-sine 2.5 ms pulse

CPU utilization matrix for AEP DIMM

NOTE: While using a 512 GB SKU configuration, you may see high CPU utilization (25% to 75%) persisting between 5 to 40 minutes when you boot into Windows Operating system.

Table 4. AEP Support Matrix

Channels		Ch5	Ch4	Ch3	Ch0	Ch1	Ch2	Ch5	Ch4	Ch3	Ch0	Ch1	Ch2												
Integrated Memory Controller		iMC1 (CPU0)					iMC0 (CPU0)					iMC0 (CPU1)			iMC1 (CPU1)										
V	P	D	D	DI	DI	DI	DI	DI	DI	DI	DI	DI	DI	DI	DI	DI	DI	DI	DI	DI	DI	DI	DI	DI	DI
M	M	I	I	M	M	M	M	M	M	M	M	M	M	M	M	M	M	M	M	M	M	M	M	M	M
((M	M	M	M	M	M	M	M	M	M	M	M	M	M	M	M	M	M	M	M	M	M	M	M
G	G	M	M	4	0	6	2	5	1	3	9	(0	(0	7	3	9	5	1	6	2	4	0	2	8	(1
))	(((((((((())))))))))))))
		0	1))))))))))))))))))))))
6	2	12		16		16			16		16		12												
4	5	8											8												
	6																								
6	51	2		16		16			16		16		25												
4	2	5											6												
	6																								
12	10	51		32		32			32		32		51												
8	2	2											2												
	6	51	12	8		8			8		8		12	12		8		8				8		8	12
4	2	8											8	8											8
	6	2	51	8		8			8		8		51	51		8		8				8		8	51
4	0	2											2	2											2
	4	4											8	8											8
	8																								
12	51	12		16		16			16		16		12	12		16		16				16		16	12
8	2	8											8	8											8

Table 4. AEP Support Matrix (continued)

Chan nels		Ch5		Ch4		Ch3		Ch0		Ch1		Ch2		Ch5		Ch4		Ch3		Ch0		Ch1		Ch2	
12 8	10 2 4	2 5 6		16		16			16		16		25 6	25 6		16		16			16		16		25 6
2 5 6	2 0 4 8	51 2		32		32			32		32		51 2	51 2		32		32			32		32		51 2

System Setup

Topics:

- General options
- System configuration
- Video
- Security
- Secure boot
- Performance
- Power management
- Post behaviour
- Manageability
- Virtualization support
- Maintenance
- System logs
- Advanced configurations
- SupportAssist system resolution
- Updating the BIOS
- MegaRAID controller options
- System and setup password

General options

Table 5. General

Option	Description
System Information	<p>This section lists the primary hardware features of your computer.</p> <p>The options are:</p> <ul style="list-style-type: none"> • System Information • Memory Configuration • Processor Information • PCI Information • Device Information
Boot Sequence	<p>Allows you to change the order in which the computer attempts to find an operating system.</p> <p>The options are:</p> <ul style="list-style-type: none"> • Diskette Drive • USB Storage Device • CD/DVD/CD-RW Drive • Onboard NIC • Internal HDD <p>Boot List Option</p> <p>Allows you to change the boot list options.</p> <p>Click one of the following options:</p> <ul style="list-style-type: none"> • Legacy • UEFI—Default

Table 5. General (continued)

Option	Description
Advanced Boot Options	Allows you to Enable Legacy Option ROMs. The options are: <ul style="list-style-type: none"> ● Enable Legacy Option ROMs—Default ● Enable Attempt Legacy Boot
UEFI Boot Path Security	Allows you to control whether the system prompts the user to enter the Admin password when booting to a UEFI boot path. Click one of the following options: <ul style="list-style-type: none"> ● Always, Except Internal HDD—Default ● Always ● Never
Date/Time	Allows you to set the date and time. The change to the system date and time takes effect immediately.

System configuration

Table 6. System Configuration



Option	Description
Integrated NIC	Allows you to configure the integrated network controller. Click one of the following options: <ul style="list-style-type: none"> ● Disabled ● Enabled ● Enabled w/PXE—Default
UEFI Network Stack	Allows pre-OS and early OS networking features to use any enabled NICs. <ul style="list-style-type: none"> ● Enabled UEFI Network Stack This option is set by default.
Serial Port	Identifies and defines the serial port settings. You can set the serial port to: <ul style="list-style-type: none"> ● Disabled ● COM1—Default ● COM2 ● COM3 ● COM4 <p> NOTE: The operating system may allocate resources even if the setting is disabled.</p>
SATA Operation	
7820 Tower	Allows you to configure the operating mode of the integrated SATA hard-drive controller. Click one of the following options: <ul style="list-style-type: none"> ● Disabled ● AHCI ● RAID On—Default <p> NOTE: SATA is configured to support RAID mode.</p>

Table 6. System Configuration (continued)

Option	Description
Drives	
7820 Tower	<p>Allows you to enable or disable various drives on board.</p> <p>The options are:</p> <ul style="list-style-type: none"> ● MiniSAS PCIe SSD-0 ● SATA-0 ● SATA-2 ● SATA-4 ● ODD-0 ● MiniSAS PCIe SSD-1 ● SATA-1 ● SATA-3 ● SATA-5 ● ODD-1 <p>All the options are set by default.</p>
PCIe Drives	<p>Allows the enabling of Front PCIe attached Ports.</p> <ul style="list-style-type: none"> ● MiniSAS PCIe SSD-0 ● MiniSAS PCIe SSD-1 ● MiniSAS PCIe SSD-2 ● MiniSAS PCIe SSD-3 <p>All the options are set by default.</p>
SMART Reporting	<p>This field controls if the hard drive errors for the integrated drives are reported during system startup. This technology is part of the SMART(Self-Monitoring Analysis and Reporting Technology) specification.</p> <ul style="list-style-type: none"> ● Enable SMART Reporting <p>This option is not set by default.</p>
USB Configuration	<p>Allows you to enable or disable the internal USB configuration.</p> <p>The options are:</p> <ul style="list-style-type: none"> ● Enable USB Boot Support ● Enable Front USB Ports ● Enable Internal USB Ports ● Enable USB 3.0 Controller ● Enable Rear USB Ports <p>All the options are set by default.</p>
Front USB Configuration	<p>Allows you to enable/disable Front USB ports.</p> <p>The options are:</p> <ul style="list-style-type: none"> ● USB3 Type A * ● USB Type C port 2 (Right) * ● USB Type C port 1 (Right) * <p>All the options are set by default.</p>
Rear USB Configuration	<p>Allows you to enable/disable Rear USB ports.</p> <p>The options are:</p> <ul style="list-style-type: none"> ● RearPort3 Top * ● RearPort1 Top *

Table 6. System Configuration (continued)

Option	Description
	<ul style="list-style-type: none"> ● RearPort2 Top * ● RearPort3 Bottom * ● RearPort1 Bottom * ● RearPort2 Bottom * <p>All the options are set by default.</p>
Internal USB Configuration	<p>Allows you to enable/disable Internal USB ports.</p> <ul style="list-style-type: none"> ● Internal Port 2 <p>This option is set by default.</p>
Dell Type-C Dock Configuration	<p>Allows you to connect to Dell WD and TB family of docks.</p> <p>Always Allows Dell Docks</p> <p>This option is set by default.</p>
Thunderbolt Adapter Configuration	<p>Allows you to enable or disable the Thunderbolt device support capability.</p> <p>The options are:</p> <ul style="list-style-type: none"> ● Enabled Thunderbolt Technology Support ● Enabled Thunderbolt Adapter Pre-boot Modules ● Enabled Thunderbolt Adapter Boot Support—Default <p> NOTE: The security level configures the Thunderbolt adapter security settings within the operating system.</p>
USB PowerShare	<p>Allows you to configure the USB PowerShare feature behavior.</p> <ul style="list-style-type: none"> ● Enable USB PowerShare <p>This option is not set by default.</p>
Audio	<p>Allows you to enable or disable the integrated audio controller.</p> <ul style="list-style-type: none"> ● Enable Audio <p>This option is set by default.</p>
Memory Map IO above 4GB	<p>Allows you to enable or disable 64-bit capable PCI devices to be decoded in above 4 GB address space(only if the system supports 64-bit PCI decoding).</p> <ul style="list-style-type: none"> ● Memory Map IO above 4GB <p>This option is not set by default.</p>
HDD Fans	<p>Allows you to control the HDD fans.</p> <p>The options are:</p> <ul style="list-style-type: none"> ● HDD1 Fan Enable ● HDD2 Fan Enable ● HDD3 Fan Enable <p>All the options are not set by default.</p>
Miscellaneous devices	<p>Allows you to enable or disable various on board devices.</p> <p>The options are:</p> <ul style="list-style-type: none"> ● Enable PCI Slot—Default ● Secure Digital (SD) Card Boot

Table 6. System Configuration (continued)

Option	Description
	<ul style="list-style-type: none"> ● Enable Secure Digital (SD) Card—Default ● Secure Digital (SD) Card Read-Only Mode
Intel VMD Technology	<p>Allows you to enable or disable VMD on the front PCIe bays.</p> <ul style="list-style-type: none"> ● PCIE0 ● PCIE1 ● PCIE0_CPU0 ● PCIE1_CPU0 <p>All the options are not set by default.</p> <p>Allows you to disable VMD for the PCIe Slots</p> <ul style="list-style-type: none"> ● Auto—Default On ● Disabled

Video

Table 7. Video

Option	Description
Primary Video Slot	<p>Allows you to configure primary boot video device.</p> <p>Click any one of the following options:</p> <ul style="list-style-type: none"> ● Auto—Default ● SLOT 1 ● SLOT 2: VGA Compatible ● SLOT 2 ● SLOT 3 ● SLOT 5 ● SLOT 6 ● SLOT7_CPU1

Security

Table 8. Security



Option	Description
Admin Password	<p>Allows you to set, change, or delete the administrator(admin) password.</p> <p>The entries to set password are:</p> <ul style="list-style-type: none"> ● Enter the old password: ● Enter the new password: ● Confirm new password: <p>Click OK once you set the password.</p> <p> NOTE: For the first time login, "Enter the old password:" field is marked to "Not set". Hence, password has to be set for the first time you login and then you can change or delete the password.</p>
System Password	<p>Allows you to set, change, or delete the System password.</p> <p>The entries to set password are:</p>

Table 8. Security (continued)

Option	Description
	<ul style="list-style-type: none"> ● Enter the old password: ● Enter the new password: ● Confirm new password: <p>Click OK once you set the password.</p> <p>i NOTE: For the first time login, "Enter the old password:" field is marked to "Not set". Hence, password has to be set for the first time you login and then you can change or delete the password.</p>
Internal HDD-0 Password	<p>Allows you to set, change, or delete the password on the system's internal hard disk drive (HDD). The entries to set password are:</p> <ul style="list-style-type: none"> ● Enter the old password: ● Enter the new password: ● Confirm new password: <p>Click OK once you set the password.</p> <p>i NOTE: For the first time login, "Enter the old password:" field is marked to "Not set". Hence, password has to be set for the first time you login and then you can change or delete the password.</p>
Strong Password	<p>Allows you to enforce the option to always set strong password.</p> <ul style="list-style-type: none"> ● Enable Strong Password <p>This option is not set by default.</p>
Password Configuration	<p>You can define the length of your password. Min = 4, Max = 32</p>
Password Bypass	<p>Allows you to bypass the System password and the Internal HDD password, when it is set, during a system restart.</p> <p>Click one of the options:</p> <ul style="list-style-type: none"> ● Disabled—Default ● Reboot bypass
Password Change	<p>Allows you to change the System password when the administrator password is set.</p> <ul style="list-style-type: none"> ● Allow Non-Admin Password Changes <p>This option is set by default.</p>
UEFI Capsule Firmware Updates	<p>Allows you to update the system BIOS via UEFI capsule update packages.</p> <ul style="list-style-type: none"> ● Enable UEFI Capsule Firmware Updates <p>This option is set by default.</p>
TPM 1.2 Security	<p>Allows you to enable or disable the Trusted Platform Module (TPM) during POST.</p> <p>The options are:</p> <ul style="list-style-type: none"> ● TPM On(Default) ● Clear ● PPI Bypass for Enable Commands ● PPI Bypass for Disable Commands <p>Click any one of the following:</p> <ul style="list-style-type: none"> ● Enabled—Default ● Disabled
Computrace (R)	<p>Allows you to activate or disable the optional Computrace software.</p>

Table 8. Security (continued)

Option	Description
	<p>The options are:</p> <ul style="list-style-type: none"> ● Deactivate—Default ● Disable ● Activate
Chassis Intrusion	<p>Allows you to control the chassis intrusion feature.</p> <p>Click one of the following options:</p> <ul style="list-style-type: none"> ● Disabled—Default ● Enabled ● On-Silent
CPU XD Support	<p>Allows you to enable the Execute Disable mode of the processor.</p> <ul style="list-style-type: none"> ● Enable CPU XD Support <p>This option is set by default.</p>
OROM Keyboard Access	<p>Allows you to determine whether users are able to enter the Option ROM Configuration screens via hotkeys during boot. The options are:</p> <p>Click one of the following options:</p> <ul style="list-style-type: none"> ● Enabled—Default ● One Time Enable ● Disabled
Admin Setup Lockout	<p>Allows you to prevent users from entering Setup when an administrator password is set.</p> <ul style="list-style-type: none"> ● Enable Admin Setup Lockout <p>This option is not set by default.</p>
Master Password Lockout	<p>Allows you to disable master password support.</p> <ul style="list-style-type: none"> ● Enable Master Password Lockout <p>This option is not set by default.</p> <p> NOTE: Hard Disk password should be cleared before the settings can be changed.</p>

Secure boot

Table 9. Secure Boot

Option	Description
Secure Boot Enable	<p>Allows you to enable or disable the Secure Boot Feature.</p> <p>Click one of the following options:</p> <ul style="list-style-type: none"> ● Disabled—Default ● Enabled
Expert Key Management	<p>Allows you to enable or disable Expert Key Management.</p> <ul style="list-style-type: none"> ● Enable Custom Mode <p>This option is not set by default.</p> <p>The Custom Mode Key Management options are:</p> <ul style="list-style-type: none"> ● PK(Default) ● KEK

Table 9. Secure Boot (continued)

Option	Description
	<ul style="list-style-type: none"> • db • dbx

Performance

Table 10. Performance

Option	Description
Multi Core Support	<p>This field specifies whether the processor has one or all cores enabled. The performance of some applications improves with the additional cores.</p> <ul style="list-style-type: none"> • Active Processor Cores <p>Choose any number from 01–08:</p> <p> NOTE: To enable Trusted Execution mode, all the cores must be enabled.</p>
Intel SpeedStep	<p>Allows you to enable or disable the Intel SpeedStep mode of processor.</p> <ul style="list-style-type: none"> • Enable Intel SpeedStep <p>This option is set by default.</p>
C-States Control	<p>Allows you to enable or disable the additional processor sleep states.</p> <ul style="list-style-type: none"> • C states <p>This option is set by default.</p>
Cache Prefetch	<p>Allows you to turn on the MLC streamer prefetcher and MLC spatial prefetcher.</p> <p>The options are:</p> <ul style="list-style-type: none"> • Hardware Prefetcher • Adjacent Cache Prefetch <p>All the options are set by default.</p>
Intel TurboBoost	<p>Allows you to enable or disable the Intel TurboBoost mode of the processor.</p> <ul style="list-style-type: none"> • Enable Intel TurboBoost <p>This option is set by default.</p>
Hyper-Thread Control	<p>Allows you to enable or disable the HyperThreading in the processor.</p> <ul style="list-style-type: none"> • Disabled • Enabled—Default
Dell Reliable Memory Technology (RMT)	<p>Allows you to identify and isolate memory errors in system RAM.</p> <ul style="list-style-type: none"> • Enable Dell RMT—Default • Clear Dell RMT
System Isochronous Mode	<p>Allows you to enable or disable this mode to reduce latency of memory transactions at the expense of bandwidth. :</p>

Table 10. Performance (continued)

Option	Description
	Click one of the options: <ul style="list-style-type: none"> ● Disabled(Default) ● Enabled
RAS Support	Allows you to report or log errors caused by memory failures, the PCIe failures, CPU failures. The options are: <ul style="list-style-type: none"> ● Enable on Memory modules ● Enable on PCIe modules ● Enable on CPU modules The options are not set by default.

Power management

Table 11. Power Management

Option	Description
AC Recovery	Specifies how the computer will respond when AC power is applied after an AC power loss. You can set the AC Recovery to: <ul style="list-style-type: none"> ● Power Off—Default ● Power On ● Last Power State
Auto On Time	Allows you to set the time at which the computer must turn on automatically. Click one of the following options: <ul style="list-style-type: none"> ● Disabled—Default ● Every Day ● Weekdays ● Select Days
Deep Sleep Control	Allows you to define the controls when Deep Sleep is enabled. Click one of the options: <ul style="list-style-type: none"> ● Disabled—Default ● Enabled in S5 only ● Enabled in S4 and S5
USB Wake Support	Allows you to enable USB devices to wake the system from standby. <ul style="list-style-type: none"> ● Enable USB Wake Support This option is set by default.
Wake on LAN	This option allows the computer to power up from the off state when triggered by a special LAN signal. Wake-up from the Standby state is unaffected by this setting and must be enabled in the operating system. This feature only works when the computer is connected to AC power supply. <ul style="list-style-type: none"> ● Disabled - Does not allow the system to power on by special LAN signals when it receives a wake-up signal from the LAN or wireless LAN. ● LAN Only - Allows the system to be powered on by special LAN signals. ● LAN with PXE Boot - Allows the system to power on and immediately boot to PXE when it receives a wake-up packet sent to the system in either the S4 or S5 state. All the options are not set by default.
Block Sleep	Allows you to block entering to sleep(S3 state) in OS Environment.

Table 11. Power Management (continued)

Option	Description
	This option is not set by default.

Post behaviour

Table 12. POST Behavior

Option	Description
Numlock LED	Specifies if the NumLock function can be enabled when the system boots. This option is set by default.
Keyboard Errors	Specifies whether keyboard related errors are reported when it boots. This option is set by default.
Extend BIOS POST Time	Allows you to create additional pre-boot delay and see POST status messages. Click one of the following options: <ul style="list-style-type: none"> ● 0 seconds(Default) ● 5 seconds ● 10 seconds
Security Audit Display Disable	Allows you to disable the display of the Security Audit results during POST. <ul style="list-style-type: none"> ● Disable Display Of Security Audit Display This option is not set by default.
Full Screen Logo	Allows you to display full screen logo, if your image matches screen resolution. <ul style="list-style-type: none"> ● Enable Full Screen Logo This option is not set by default.
Warnings and Errors	Allows you to select different options to either stop, prompt and wait for user input, continue when warnings are detected but pause on errors, or continue when either warnings or errors are detected during the POST process. Click one of the following options: <ul style="list-style-type: none"> ● Prompt on Warnings and Errors—Default ● Continue on Warnings ● Continue on Warnings and Errors

Manageability

Table 13. Manageability

Option	Description
USB Provision	Allows you to provision Intel AMT using the local provisioning file via a USB storage device. <ul style="list-style-type: none"> ● Enable USB Provision <p> NOTE: When disabled, provisioning Intel AMT from a USB storage device is blocked.</p> This option is not set by default.
MEBx Hotkey	Allows you to specify if the MEBx Hotkey function should be enabled when the system boots

Table 13. Manageability (continued)

Option	Description
	This option is set by default.

Virtualization support

Table 14. Virtualization Support

Option	Description
Virtualization	<p>This option specifies whether a Virtual Machine Monitor (VMM) can utilize the additional hardware capabilities provided by the Intel Virtualization technology.</p> <ul style="list-style-type: none"> • Enable Intel Virtualization Technology <p>This option is set by default.</p>
VT for Direct I/O	<p>Enables or disables the Virtual Machine Monitor (VMM) from utilizing the additional hardware capabilities provided by the Intel Virtualization technology for direct I/O.</p> <ul style="list-style-type: none"> • Enable VT for Direct I/O <p>This option is set by default.</p>
Trusted Execution	<p>Allows you to specify whether a Measured Virtual Machine Monitor (MVMM) can utilize the additional hardware capabilities provided by the Intel Trusted Execution Program.</p> <ul style="list-style-type: none"> • Trusted Execution <p>This option is not set by default.</p>

Maintenance

Table 15. Maintenance

Option	Description
Service Tag	Displays the service tag of your computer.
Asset Tag	<p>Allows you to create a system asset tag if an asset tag is not already set.</p> <p>This option is not set by default.</p>
SERR Messages	<p>Controls the SERR message mechanism. Some graphics cards require that the SERR message mechanism be disabled.</p> <p>This option is not set by default.</p>
BIOS Downgrade	<p>Allows you to flash previous revisions of the system firmware.</p> <ul style="list-style-type: none"> • Allow BIOS Downgrade <p>This option is set by default.</p>
Data Wipe	<p>Allows you to securely erase data from all internal storage devices.</p> <ul style="list-style-type: none"> • Wipe on Next Boot <p>This option is not set by default.</p>
Bios Recovery	<p>BIOS Recovery from Hard Drive—This option is set by default. Allows you to recover the corrupted BIOS from a recovery file on the HDD or an external USB key.</p> <p>BIOS Auto-Recovery— Allows you to recover the BIOS automatically.</p>

Table 15. Maintenance (continued)

Option	Description
	<p> NOTE: BIOS Recovery from Hard Drive field should be enabled.</p> <p>Always Perform Integrity Check—Performs integrity check on every boot.</p>

System logs

Table 16. System Logs

Option	Description
BIOS events	<p>Displays the system event log and allows you to clear the log.</p> <ul style="list-style-type: none">• Clear Log <p>This option is not set by default.</p>

Advanced configurations

Table 17. Advanced configurations

Option	Description
Pcie LinkSpeed	<p>Allows you to choose the Pcie linkspeed.</p> <p>Click one of the following options:</p> <ul style="list-style-type: none">• Auto—Default• Gen1• Gen2

SupportAssist system resolution

Table 18. SupportAssit System Resolution

Option	Description
Auto OS Recovery Threshold	<p>The Auto OS Recovery Threshold setup option controls the automatic boot flow for Support Assist System Resolution Console and Dell OS Recovery tool.</p> <p>Click one of the following options:</p> <ul style="list-style-type: none">• OFF• 1• 2—Default• 3

Updating the BIOS

Updating the BIOS in Windows

1. Go to www.dell.com/support.
2. Click **Product support**. In the **Search support** box, enter the Service Tag of your computer, and then click **Search**.

 **NOTE:** If you do not have the Service Tag, use the SupportAssist feature to automatically identify your computer. You can also use the product ID or manually browse for your computer model.

3. Click **Drivers & Downloads**. Expand **Find drivers**.
4. Select the operating system installed on your computer.
5. In the **Category** drop-down list, select **BIOS**.
6. Select the latest version of BIOS, and click **Download** to download the BIOS file for your computer.
7. After the download is complete, browse the folder where you saved the BIOS update file.
8. Double-click the BIOS update file icon and follow the on-screen instructions.

For more information about how to update the system BIOS, search in the Knowledge Base Resource at www.dell.com/support.

Updating the BIOS in Linux and Ubuntu

To update the system BIOS on a computer that is installed with Linux or Ubuntu, see the knowledge base article [000131486](https://www.dell.com/support) at www.dell.com/support.

Updating the BIOS using the USB drive in Windows

1. Follow the procedure from step 1 to step 6 in [Updating the BIOS in Windows](#) to download the latest BIOS setup program file.
2. Create a bootable USB drive. For more information, search the Knowledge Base Resource at www.dell.com/support.
3. Copy the BIOS setup program file to the bootable USB drive.
4. Connect the bootable USB drive to the computer that needs the BIOS update.
5. Restart the computer and press **F12**.
6. Select the USB drive from the **One Time Boot Menu**.
7. Type the BIOS setup program filename and press **Enter**.
The **BIOS Update Utility** appears.
8. Follow the on-screen instructions to complete the BIOS update.

Updating the BIOS from the F12 One Time Boot menu

Update your computer BIOS using the BIOS update.exe file that is copied to a FAT32 USB drive and booting from the F12 **One Time Boot** menu.

BIOS Update

You can run the BIOS update file from Windows using a bootable USB drive or you can also update the BIOS from the F12 **One Time Boot** menu on the computer.

Most of the Dell computers built after 2012 have this capability, and you can confirm by booting your computer to the F12 **One Time Boot** Menu to see if BIOS FLASH UPDATE is listed as a boot option for your computer. If the option is listed, then the BIOS supports this BIOS update option.

 **NOTE:** Only computers with the BIOS Flash Update option in the F12 **One Time Boot** menu can use this function.

Updating from the One Time Boot menu

To update your BIOS from the F12 **One Time Boot** menu, you need the following:

- USB drive formatted to the FAT32 file system (key does not have to be bootable)
- BIOS executable file that you downloaded from the Dell Support website and copied to the root of the USB drive
- AC power adapter that is connected to the computer
- Functional computer battery to flash the BIOS

Perform the following steps to perform the BIOS update flash process from the F12 menu:

 **CAUTION:** Do not turn off the computer during the BIOS update process. The computer may not boot if you turn off your computer.

1. From a turn off state, insert the USB drive where you copied the flash into a USB port of the computer.

2. Turn on the computer and press F12 to access the **One Time Boot** Menu, select BIOS Update using the mouse or arrow keys then press Enter.
The flash BIOS menu is displayed.
3. Click **Flash from file**.
4. Select an external USB device.
5. Select the file and double-click the flash target file, and then click **Submit**.
6. Click **Update BIOS**. The computer restarts to flash the BIOS.
7. The computer will restart after the BIOS update is completed.

MegaRAID controller options

During bootup, press <Ctrl> + <R> when prompted by the BIOS screen to get to the BIOS configuration utility.

Table 19. MegaRAID configuration utility

Option	Description
VD Mgmt (Virtual Device Management)	<p>This option is used to import the existing configuration to the RAID controller or clear the existing configuration. The right-hand panel of the screen lists attributes of the virtual drive or other device selected in the left panel.</p> <ul style="list-style-type: none"> ● Virtual Drives ● Drives ● Available size ● Hot spare drives
PD Mgmt (Physical Drive Management)	<p>This screen displays basic information about existing physical drives connected to the selected controller, including drive ID, vendor, size, type, and state and allows you to manage physical drives.</p> <p>Press F2 to show the context menu:</p> <ul style="list-style-type: none"> ● Rebuild ● Copyback ● Locate ● Place Drive online ● Place drive offline ● Make Global HS ● Remove Hot Spare drive ● Make JBOD ● Make unconfigured good ● Prepare for Removal
Ctrl Mgmt (Control Management)	<p>This screen allows you to change the settings for controller options such as Enable Controller BIOS, Enable BIOS Stop on Error and others. It also allows you to select a bootable virtual drive, restore default controller settings.</p>
Properties	<p>The Properties screen displays the controller properties like current versions of the controller BIOS, the MegaRAID firmware the Configuration Utility and the Boot block.</p>

 **NOTE:** Press <Ctrl> + <N> to move to the next screen and Press <Ctrl> + <P> to go back to the previous screen.

System and setup password

Table 20. System and setup password

Password type	Description
System password	Password that you must enter to log on to your system.
Setup password	Password that you must enter to access and make changes to the BIOS settings of your computer.

You can create a system password and a setup password to secure your computer.

 **CAUTION:** The password features provide a basic level of security for the data on your computer.

 **CAUTION:** Anyone can access the data stored on your computer if it is not locked and left unattended.

 **NOTE:** System and setup password feature is disabled.

Assigning a system setup password

You can assign a new **System or Admin Password** only when the status is in **Not Set**.

To enter the system setup, press F2 immediately after a power-on or reboot.

1. In the **System BIOS** or **System Setup** screen, select **Security** and press **Enter**.
The **Security** screen is displayed.
2. Select **System/Admin Password** and create a password in the **Enter the new password** field.
Use the following guidelines to assign the system password:
 - A password can have up to 32 characters.
 - The password can contain the numbers 0 through 9.
 - Only lower case letters are valid, upper case letters are not allowed.
 - Only the following special characters are allowed: space, ("), (+), (.), (-), (.), (/), (;), ([), (\), (]), (').
3. Type the system password that you entered earlier in the **Confirm new password** field and click **OK**.
4. Press **Esc** and a message prompts you to save the changes.
5. Press **Y** to save the changes.
The computer reboots.

Deleting or changing an existing system setup password

Ensure that the **Password Status** is Unlocked (in the System Setup) before attempting to delete or change the existing System and Setup password. You cannot delete or change an existing System or Setup password, if the **Password Status** is Locked.

To enter the System Setup, press **F2** immediately after a power-on or reboot.

1. In the **System BIOS** or **System Setup** screen, select **System Security** and press **Enter**.
The **System Security** screen is displayed.
2. In the **System Security** screen, verify that **Password Status** is **Unlocked**.
3. Select **System Password**, alter or delete the existing system password and press **Enter** or **Tab**.
4. Select **Setup Password**, alter or delete the existing setup password and press **Enter** or **Tab**.
 **NOTE:** If you change the System and/or Setup password, re enter the new password when prompted. If you delete the System and Setup password, confirm the deletion when prompted.
5. Press **Esc** and a message prompts you to save the changes.
6. Press **Y** to save the changes and exit from System Setup.
The computer restarts.

Software

This chapter details the supported operating systems along with instructions on how to install the drivers.

Topics:

- [Operating system](#)
- [Downloading drivers](#)
- [Chipset drivers](#)
- [Graphics controller driver](#)
- [Ports](#)
- [USB drivers](#)
- [Network driver](#)
- [Audio drivers](#)
- [Storage controller drivers](#)
- [Other drivers](#)

Operating system

Your Precision 7820 Tower supports the following operating systems:

- Windows 11 Pro, 64-bit
- Windows 11 Pro National Academic, 64-bit
- Windows 11 Pro for Workstations, 64-bit
- Windows 10 Pro, 64-bit
- Windows 10 Pro National Academic, 64-bit
- Windows 10 Enterprise, 64-bit *
- Windows 10 Pro for Workstation, 64-bit
- RHEL 8.4
- Ubuntu 20.04 LTS, 64-bit
- Neokylin 10

 **NOTE:** Asterisk(*): means that "Only supported on systems with Xeon W Series CPUs."

Downloading drivers

1. Turn on the computer.
2. Go to **Dell.com/support**.
3. Click **Product Support**, enter the Service Tag of your system, and then click **Submit**.

 **NOTE:** If you do not have the Service Tag, use the auto detect feature or manually browse for your system model.

4. Click **Drivers and Downloads**.
5. Select the operating system installed on your system.
6. Scroll down the page and select the driver to install.
7. Click **Download File** to download the driver for your system.
8. After the download is complete, navigate to the folder where you saved the driver file.
9. Double-click the driver file icon and follow the instructions on the screen.

Chipset drivers

Verify if the Intel chipset and Intel Management Engine Interface drivers are already installed in the computer.

- System devices
 - ACPI Fixed Feature Button
 - ACPI Module Device
 - Advanced programmable interrupt controller
 - Composite Bus Enumerator
 - Direct memory access controller
 - High Definition Audio Controller
 - High Definition Audio Controller
 - Intel(R) C620 series chipset CSME: IDE Redirection - A1BC
 - Intel(R) C620 series chipset LPC Controller - A1C1
 - Intel(R) C620 series chipset MROM 0 - A1EC
 - Intel(R) C620 series chipset MROM 1 - A1ED
 - Intel(R) C620 series chipset PCI Express Root Port #1 - A190
 - Intel(R) C620 series chipset PCI Express Root Port #8 - A197
 - Intel(R) C620 series chipset PMC - A1A1
 - Intel(R) C620 series chipset SMBus - A1A3
 - Intel(R) C620 series chipset SPI Controller - A1A4
 - Intel(R) C620 series chipset Thermal Subsystem - A1B1
 - Intel(R) Management Engine Interface
 - Intel(R) Xeon(R) processor P family/Core i7 CBDMA Registers - 2021
 - Intel(R) Xeon(R) processor P family/Core i7 CBDMA Registers - 2021
 - Intel(R) Xeon(R) processor P family/Core i7 CBDMA Registers - 2021
 - Intel(R) Xeon(R) processor P family/Core i7 CBDMA Registers - 2021
 - Intel(R) Xeon(R) processor P family/Core i7 CBDMA Registers - 2021
 - Intel(R) Xeon(R) processor P family/Core i7 CBDMA Registers - 2021
 - Intel(R) Xeon(R) processor P family/Core i7 CBDMA Registers - 2021
 - Intel(R) Xeon(R) processor P family/Core i7 CBDMA Registers - 2021
 - Intel(R) Xeon(R) processor P family/Core i7 CBDMA Registers - 2021
 - Intel(R) Xeon(R) processor P family/Core i7 CHA Registers - 2057
 - Intel(R) Xeon(R) processor P family/Core i7 CHA Registers - 2054
 - Intel(R) Xeon(R) processor P family/Core i7 CHA Registers - 2056
 - Intel(R) Xeon(R) processor P family/Core i7 CHA Registers - 2055
 - Intel(R) Xeon(R) processor P family/Core i7 CHA Registers - 208E

Graphics controller driver

Verify if the graphics controller driver is already installed in the computer.

- Display adapters
 - NVIDIA NVS 310

Ports

Verify if the drivers for the ports are already installed in the computer.

- Ports (COM & LPT)
 - Communications Port (COM1)
 - Intel(R) Active Management Technology - SOL (COM3)

USB drivers

Verify if the USB drivers are already installed in the computer.

- Universal Serial Bus controllers
 - Generic SuperSpeed USB Hub
 - Generic USB Hub
 - Intel(R) USB 3.0 eXtensible Host Controller - 1.0 (Microsoft)
 - USB Composite Device
 - USB Mass Storage Device
 - USB Root Hub (xHCI)

Network driver

The driver is labeled as Intel I219-LM Ethernet Driver.

- Network adapters
 - Intel(R) Ethernet Connection (3) I219-LM

Audio drivers

Verify if the audio drivers are already installed in the computer.

- Sound, video and game controllers
 - NVIDIA High Definition Audio
 - Realtek Audio
- Audio inputs and outputs
 - Speakers / Headphones (Realtek Audio)

Storage controller drivers

Verify if the storage controller drivers are already installed in the computer.



- Storage controllers
 - Intel(R) C600+/C220+ series chipset SATA RAID Controller
 - Microsoft Storage Spaces Controller

Other drivers

This section lists different driver details for all the other components in the Device Manager.

Security device drivers

Verify if the security device drivers are already installed in the computer.

- ▼  Security devices
 -  Trusted Platform Module 1.2



Software device drivers

Verify if the software device drivers are already installed in the computer.

- ▼  Software devices
 -  Microsoft Device Association Root Enumerator
 -  Microsoft GS Wavetable Synth



Human Interface Device drivers

Verify if the human interface device drivers are already installed in the computer.

- ▼  Human Interface Devices
 -  USB Input Device

Firmware

Verify if the Firmware drivers are already installed in the computer.

- ▼  Firmware
 -  System Firmware

Troubleshooting

The following section describes common troubleshooting steps that can be performed to resolve certain problems on your computer.

Topics:

- [Dell Enhanced Pre-Boot System Assessment — ePSA Diagnostic 3.0](#)
- [Hard drive indicator codes](#)
- [Preboot blinking power button codes](#)

Dell Enhanced Pre-Boot System Assessment — ePSA Diagnostic 3.0

You can invoke the ePSA diagnostics by either of the following ways :

- Press the F12 key when the system posts and choose **ePSA or Diagnostics** option on One Time Boot Menu.
- Press and hold Fn(Function key on keyboard) and **Power On** (PWR) the system.

Running the ePSA Diagnostics

Invoke diagnostics boot by either of the methods that are suggested below:

1. Power on the computer.
2. As the computer boots, press the F12 key when the Dell logo is displayed.
3. In the boot menu screen, use Up/Down arrow key to select the **Diagnostics** option and then press **Enter**.
 **NOTE:** The **Enhanced Pre-boot System Assessment** window displays, listing all devices detected in the computer. The diagnostics starts running the tests on all the detected devices.
4. Press the arrow in the lower-right corner to go to the page listing. The detected items are listed and tested.
5. To run a diagnostic test on a specific device, press Esc and click **Yes** to stop the diagnostic test.
6. Select the device from the left pane and click **Run Tests**.
7. If there are any issues, error codes are displayed. Note the error code and contact Dell.

Hard drive indicator codes

Each hard drive carrier has an activity LED indicator and a status LED indicator. The indicators provide information about the current status of the hard drive. The activity LED indicator indicates whether the hard drive is currently in use or not. The status LED indicator indicates the power condition of the drive.

Hard drive indicators

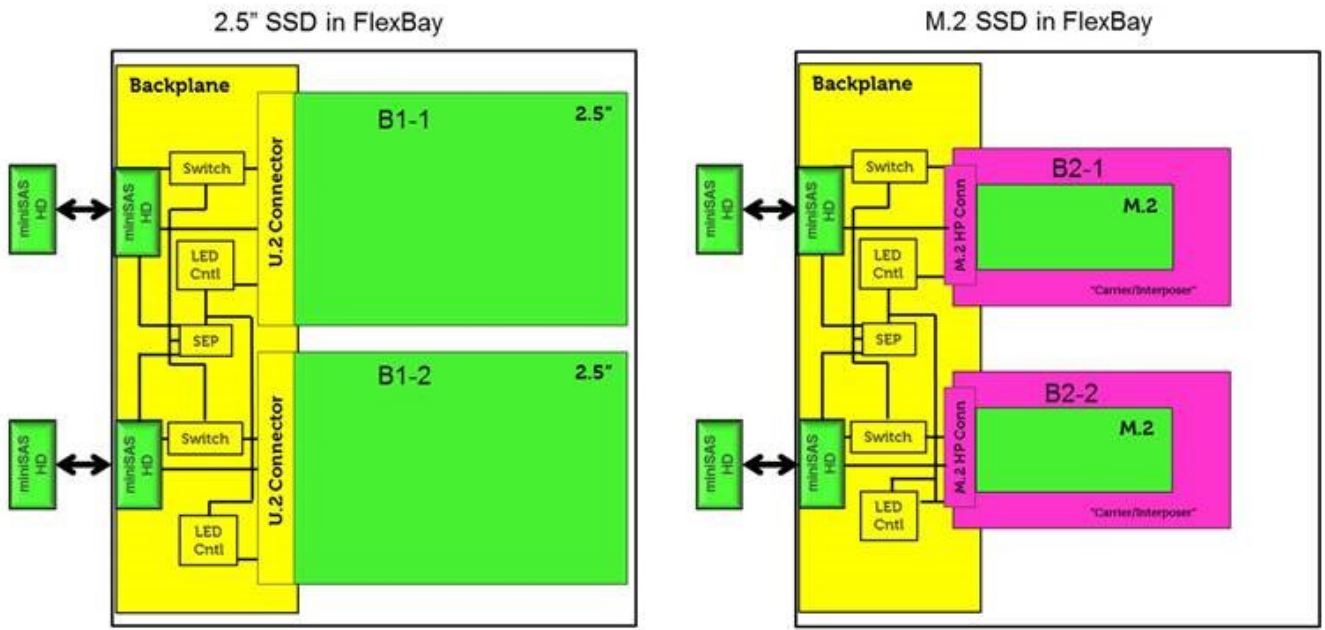

NOTE: LED status or activity indicators will only work with a backplane with each carriers shown below.

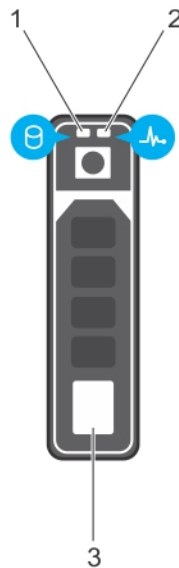

Figure 3. Hard drive indicators

1. hard drive activity LED indicator
2. hard drive status LED indicator
3. hard drive

NOTE: If the hard drive is in the Advanced Host Controller Interface (AHCI) mode, the status LED indicator does not turn on.

NOTE: Drive status indicator behavior is managed by Storage Spaces Direct. Not all drive status indicators may be used.

Table 21. Hard drive indicator codes

Hard drive status indicator code	Condition
Flashes green twice per second	Identifying drive or preparing for removal.
Off	Drive ready for removal. NOTE: The drive status indicator remains off until all drives are initialized after the system is turned on. Drives are not ready for removal during this time.
Flashes green, amber, and then turns off	Predicted drive failure.
Flashes amber four times per second	Drive failed.
Flashes green slowly	Drive rebuilding.
Solid green	Drive online.
Flashes green for three seconds, amber for three seconds, and then turns off after six seconds	Rebuild stopped.

Preboot blinking power button codes

Table 22. Power button LED state

Power Button LED State	Description
Off	Power is Off. LED is blank.
Blinking Amber	Initial State of LED at power up. See the table below for Blinking Amber pattern diagnostic suggestions and possible failures.
Blinking White	System is in a low power state, either S1 or S3. This does not indicate a fault condition.
Solid Amber	The second state of the LED at power up, indicates that the POWER_GOOD signal is active and it is probable that the power supply is fine.
Solid White	System is in S0 state. This is the normal power states of a functioning machine. The BIOS will turn the LED to this states to indicate it has started fetching op-codes.

Table 23. Diagnostic LED behavior

Blinking pattern		Problem description	Suggested resolution
Amber	White		
1	1	Faulty System board	To troubleshoot the issue with system board, contact Tech support.
1	2	Bad Power_Ctrl Cable, System Board or, PSU	<ul style="list-style-type: none"> Make sure Power_Ctrl Cable is connected. Remove PSU and test BIST button outside of the system first, if failed, replace PSU. If not, install

Table 23. Diagnostic LED behavior (continued)

Blinking pattern		Problem description	Suggested resolution
Amber	White		
			<ul style="list-style-type: none"> back the PSU and test the BIST button again. If nothing works, contact Tech Support for system board replacement
1	3	Bad system board, Memory or Processor	<ul style="list-style-type: none"> If you can assist to troubleshoot, narrow down the issue by reseating memory and swapping a known good memory if available. If nothing works, contact Tech Support
2	1	Bad Processor	<ul style="list-style-type: none"> CPU configuration activity is in progress or a CPU failure was detected. Contact Tech Support If you can assist to troubleshoot, narrow down the issue by ensuring CPU 0 is installed, CPU0 and CPU1 is an identical matching pair and swapping a known good CPU if available. If nothing works, contact Tech Support
2	2	Motherboard: BIOS ROM failure	<ul style="list-style-type: none"> System is in Recovery Mode. Flash latest BIOS version. If problem persists, contact Tech Support
2	3	No Memory	<ul style="list-style-type: none"> If customer can assist to troubleshoot, narrow down the issue by removing the memory module one by one to determine which one failed and swapping to a known good memory if available to confirm. Contact Tech Support
2	4	Memory/RAM failure	<ul style="list-style-type: none"> If customer can assist to troubleshoot, narrow down the issue by removing the memory module one by one to determine which one failed and swapping to a known good memory if available to confirm. Contact Tech Support
2	5	Invalid memory installed	<ul style="list-style-type: none"> Memory subsystem configuration activity is

Table 23. Diagnostic LED behavior (continued)

Blinking pattern		Problem description	Suggested resolution
Amber	White		
			<p>in progress. Memory modules have been detected but appear to be incompatible or in an invalid configuration.</p> <ul style="list-style-type: none"> • If customer can assist to troubleshoot, narrow down the issue by removing one by one the memory on motherboard to determine which one failed. • Contact Tech Support.
2	6	Motherboard: Chipset	<ul style="list-style-type: none"> • Fatal system board failure detected. • If customer can assist to troubleshoot, narrow down the issue by removing one by one the component on motherboard to determine which one failed. • If you identified any of the components failed, replace the Component. • Contact Tech Support.
3	2	PCI Device or Video	<ul style="list-style-type: none"> • PCI device configuration activity is in progress or PCI device failure was detected. • If you can assist to troubleshoot, narrow down the issue by reseating PCI card and removing one by one to determine which card failed. • Contact Tech Support.
3	3	BIOS Recovery 1	<ul style="list-style-type: none"> • System is in Recovery Mode. • Flash latest BIOS version. If problem persists, contact Tech Support
3	4	BIOS Recovery 2	<ul style="list-style-type: none"> • System is in Recovery Mode. • Flash latest BIOS version. If problem persists, contact Tech Support
4	4	Riser board issue	<ul style="list-style-type: none"> • Power issue on Riser second CPU board
4	6	RAID Volume degraded	<ul style="list-style-type: none"> • RAID volume is degraded. • If you can assist to troubleshoot, us F12 menu to enter Device

Table 23. Diagnostic LED behavior (continued)

Blinking pattern		Problem description	Suggested resolution
Amber	White		
			Configuration tab. Rebuild the RAID volume if possible <ul style="list-style-type: none"> • Contact Tech Support.
4	7	System Side cover is missing	<ul style="list-style-type: none"> • System side cover(either left or right) is missing. • Unplug power, Install back all side covers back to the chassis and plug in power. • Contact Tech Support.

Contacting Dell

 **NOTE:** If you do not have an active Internet connection, you can find contact information on your purchase invoice, packing slip, bill, or Dell product catalog.

Dell provides several online and telephone-based support and service options. Availability varies by country and product, and some services may not be available in your area. To contact Dell for sales, technical support, or customer service issues:

1. Go to **Dell.com/support**.
2. Select your support category.
3. Verify your country or region in the **Choose a Country/Region** drop-down list at the bottom of the page.
4. Select the appropriate service or support link based on your need.